



Message Implementation Guideline

VDA 4938 T2 - GLOBAL INVOIC

based on

INVOIC

Invoice message

UN D.07A S3

Version: V1.2 - 2013
Variant: Rechnung Continental Automotive
Issue date: 05.11.2013
Author: CONTINENTAL

Structure / Table of Contents

Tag	St	MaxOcc	Content
UNA	O	1	Service string advice UNA:+.? '
UNB	M	1	Interchange header UNB+UNOA:3+OD012345:59:123+987654321:1:X+071205:1446+144659+++++1'
UNH	M	1	Message header UNH+1+INVOIC:D:07A:UN:GAVA12'
BGM	M	1	Type of invoice and invoice number BGM+380::272:Rechnung+Rechnungsnummer+9'
DTM	M	1	Message date DTM+137:20131125:102'
DTM	R	1	Delivery or Service Completion Date DTM+1:20100308:102'
FTX	O	99	Legal info free text FTX+REG+++Text:Text:Text:Text:Text+de'
FTX	O	99	Payment instructions free text FTX+AAB+++Text:Text:Text:Text:Text+de'
FTX	O	99	General information free text FTX+AAI+++Text:Text:Text:Text:Text+de'
GEI	O	1	Processing indicator GEI+PM+::272'
SG2	R	1	Buyer
NAD	M	1	Buyer's Name and Address NAD+BY+Identifier::91+++Name:Name+Strasse+Ort++PLZ+DE'
SG3	R	1	Buyer's VAT reference number
RFF	M	1	Buyer's reference number(s) RFF+VA:7656444'
SG5	O	1	Information contact
CTA	M	1	Contact information CTA+IC+X:X'
COM	O	4	Communication contact COM+08154711:TE'
SG2	R	1	Seller
NAD	M	1	Seller's name and address NAD+SE+Identifier::92+++Name:Name+Strasse+Ort++PLZ+DE'
SG3	O	1	Seller's VAT reference number(s)
RFF	M	1	Sellers's reference number(s) RFF+VA:Umsatzsteuernummer des Verkäufers'
SG5	O	1	Information contact
CTA	M	1	Information contact CTA+IC+Abteilung:Name'
COM	O	5	Communication contact COM+08154711:TE'
SG2	R	1	Invoicee
NAD	M	1	Invoicee's name and address NAD+IV+Identifier::92+++Name:Name+Strasse+Ort++PLZ+DE'
SG2	O	1	Invoice Issuer

MaxOcc = Maximum occurrence of the segment/group St = Status: M=Mandatory, C=Conditional, R=Required, O=Optional, D=Dependent, A=Advised, N=Not used



Tag	St	MaxOcc	Content
NAD	M	1	Invoice Issuer's name and address NAD+II+Identifier::92++Name:Name+Strasse+Ort++PLZ+DE'
SG2	R	1	Ship-to
NAD	M	1	Ship-to's name and address NAD+ST+Identifier::92++Name:Name+Strasse+Ort++PLZ+DE'
SG5	O	1	Ship-to's delivery contact
CTA	M	1	Ship-to's delivery contact CTA+DL+Abteilung:Name'
COM	O	1	Communication contact COM+08154711:EM'
SG7	R	1	Invoice currency
CUX	M	1	Currencies CUX+2:EUR:4+3:AED:1:9+++AAA'
SG8	R	10	Payment instructions
PYT	M	1	Payment terms PYT+1++++D+90'
DTM	R	1	Payment due date DTM+140:20131212:102'
DTM	O	1	Reference date/time DTM+171:20131212:102'
PCD	R	1	Discount, payment or instalment percentage PCD+12:2'
MOA	O	1	Instalment or payment discount amount MOA+52:9:EUR'
MOA	D	1	Monetary amount MOA+372:9:EUR'
PAI	D	1	Payment instructions PAI+::49'
FII	R	1	Financial institution information FII+RH+4433221100:Iron Parts Ltd.+10090000::17::::Volksbank'
SG9	O	1	Transport details
TDT	M	1	Transport information TDT+12++20'
SG26	R	900	Line item section
LIN	M	1	Line item and article nuber LIN+1++1234567890:IN'
PIA	O	1	Additional article identifier(s) 1 PIA+1+1234:SA'
IMD	R	1	Description of article or service IMD+++:::Beschreibung'
QTY	R	1	Invoiced quantity QTY+47:9:C62'
ALI	O	1	Country of origin, customs information and booking key ALI+DE'
FTX	O	99	Terms of delivery text FTX+AAR+++Text:Text:Text:Text:Text+de'
FTX	O	99	Tax exemption reason text FTX+TXD+++Text:Text:Text:Text:Text+de'

MaxOcc = Maximum occurrence of the segment/group St = Status: M=Mandatory, C=Conditional, R=Required, O=Optional, D=Dependent, A=Advised, N=Not used

Tag	St	MaxOcc	Content
FTX	O	99	General text information FTX+AAI+++Text:Text:Text:Text:Text+de'
SG27	R	1	Line item net amount
MOA	M	1	Line item net amount in invoice currency MOA+203:9:EUR'
SG29	R	1	Calculation net price
PRI	M	1	Price details PRI+AAA:9::CON::PCE'
SG30	O	1	Frame contract (blanket order) / Order / Purchase order
RFF	M	1	Frame contract (blanket order) / Order / Purchase order RFF+ON:Bestellnummer:1'
SG30	O	1	Despatch note / delivery note (synonym)
RFF	M	1	Reference message number RFF+AAU:Lieferscheinnummer:1'
SG34	R	1	VAT rate and amount for line item
TAX	M	1	VAT or other tax rate TAX+7+VAT+++::19+AA+++1'
SG39	O	10	Allowances or charges
ALC	M	1	Allowance/charge ALC+C+++AAK::272'
FTX	O	1	Allowance/charge description FTX+ALC+++Text:Text:Text:Text+de'
SG41	D	1	Allowance/charge - percentage
PCD	M	1	Allowance/charge Percentage PCD+3:9'
SG42	D	1	Allowance/charge - monetary amount
MOA	M	1	Allowance/charge - monetary amount MOA+8:9:EUR'
SG43	O	1	Allowance / charge rate per unit
RTE	M	1	Rate details RTE+1:10.00'
SG47	R	1	Terms of delivery
TOD	M	1	Terms of delivery - incoterms TOD+++CFR::4'
LOC	O	1	Place/location identification LOC+1+:::Ort'
UNS	M	1	Section control UNS+S'
SG50	R	3	Invoice amount
MOA	M	1	Invoice amount MOA+77:1000:EUR'
SG50	D	3	Total taxable amount
MOA	M	1	Total taxable amount MOA+125:9:EUR'
SG50	O	3	Total line items amount
MOA	M	1	Total line items amount (sum of net line items amounts) MOA+79:9:EUR'
SG50	D	1	Total invoice additional amount

MaxOcc = Maximum occurrence of the segment/group St = Status: M=Mandatory, C=Conditional, R=Required, O=Optional, D=Dependent, A=Advised, N=Not used



Tag	St	MaxOcc	Content
MOA	M	1	Total invoice additional amount MOA+136:9:EUR'
SG50	D	1	Tax amount
MOA	M	1	Tax amount MOA+176:9:EUR'
SG50	O	2	Non-taxable / exemption amount
MOA	M	1	Non-taxable or exemption amount MOA+403:9:EUR'
SG52	R	10	Tax rates and amounts
TAX	M	1	Tax type and rate TAX+7+VAT+++:::19++++1'
MOA	R	1	Tax amount in invoice currency MOA+124:9:EUR'
MOA	R	1	Taxable amount in invoice currency MOA+125:9:EUR'
MOA	R	1	Invoice amount in invoice currency MOA+128:9:EUR'
SG53	D	15	Delivery costs
ALC	M	1	Charge ALC+C+++ABK::272'
MOA	R	1	Charge amount MOA+8:9:EUR'
FTX	O	1	Charge description text FTX+ALC+++Text:Text:Text:Text:Text+de'
UNT	M	1	Message trailer UNT+64+1'
UNZ	M	1	Interchange trailer UNZ+1+144659'

MaxOcc = Maximum occurrence of the segment/group St = Status: M=Mandatory, C=Conditional, R=Required, O=Optional, D=Dependent, A=Advised, N=Not used

Branching Diagram of Used Segments/Groups

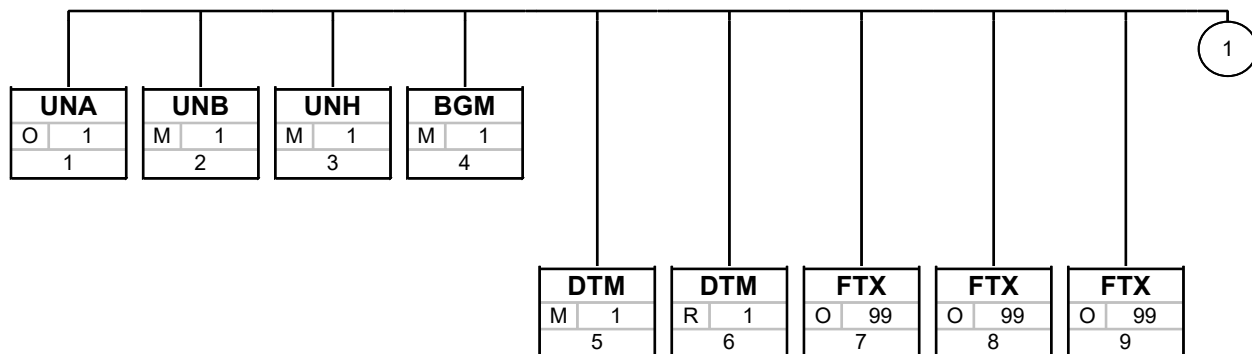

Tag
St MaxOcc
No

Tag = Segment/Group Tag
 St = Status: M=Mandatory, C=Conditional, R=Required, O=Optional, D=Dependent, A=Advised, N=Not used
 MaxOcc = Maximum occurrence of the segment/group
 No = Consecutive segment number

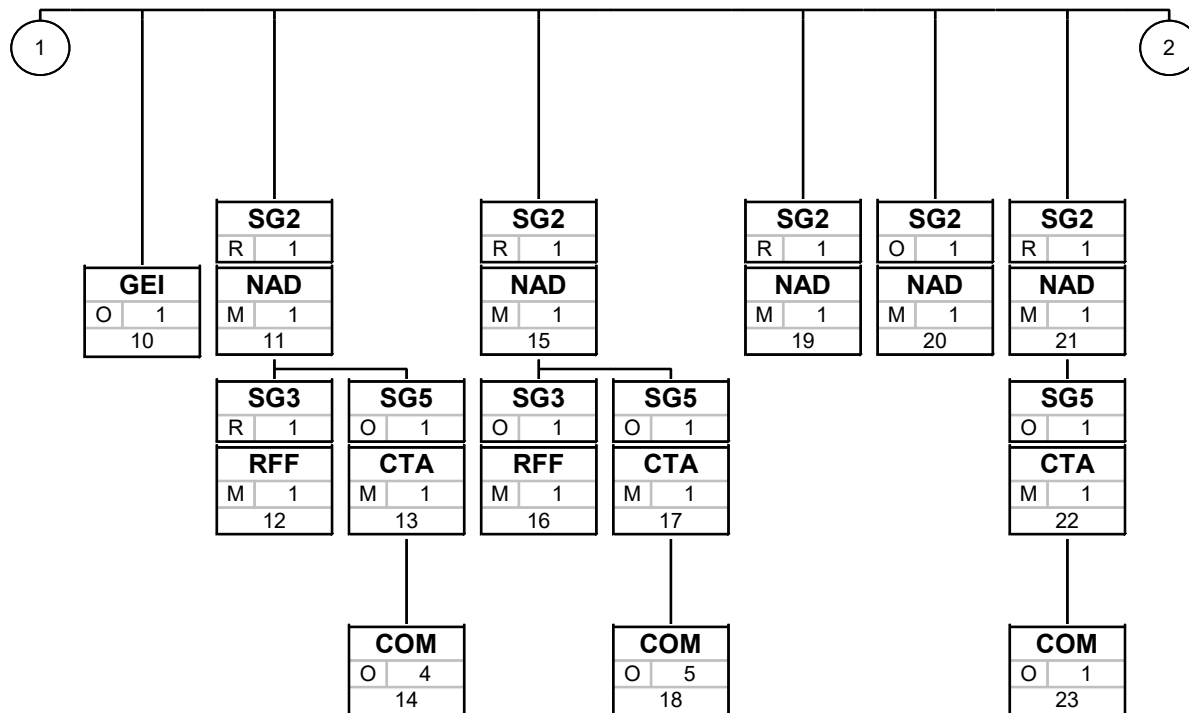

Tag
St MaxOcc
No

Tag = Segment/Group Tag
 St = Status: M=Mandatory, C=Conditional, R=Required, O=Optional, D=Dependent, A=Advised, N=Not used
 MaxOcc = Maximum occurrence of the segment/group
 No = Consecutive segment number

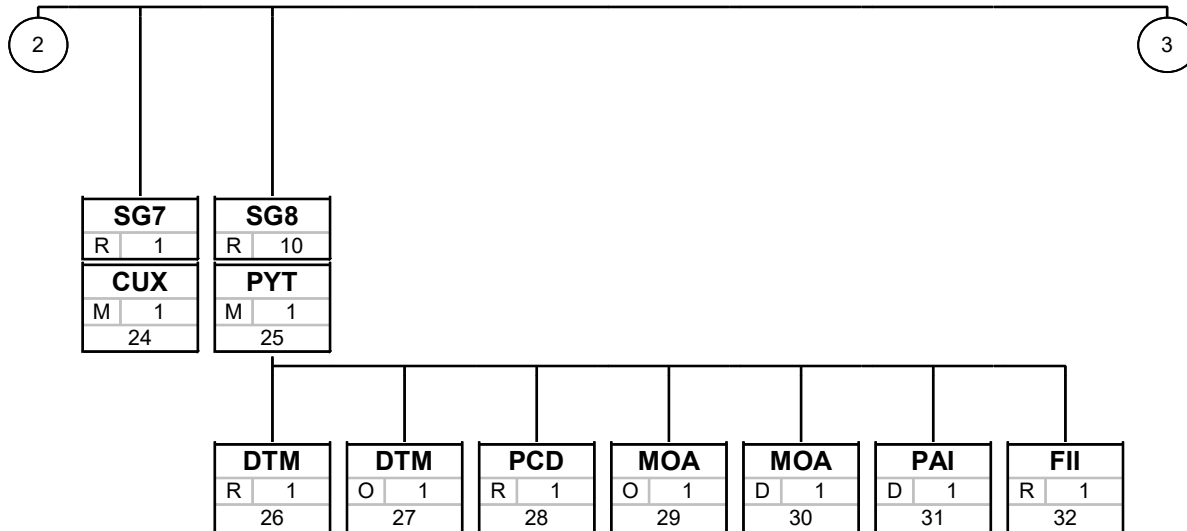

Tag
St MaxOcc
No

Tag = Segment/Group Tag
 St = Status: M=Mandatory, C=Conditional, R=Required, O=Optional, D=Dependent, A=Advised, N=Not used
 MaxOcc = Maximum occurrence of the segment/group
 No = Consecutive segment number

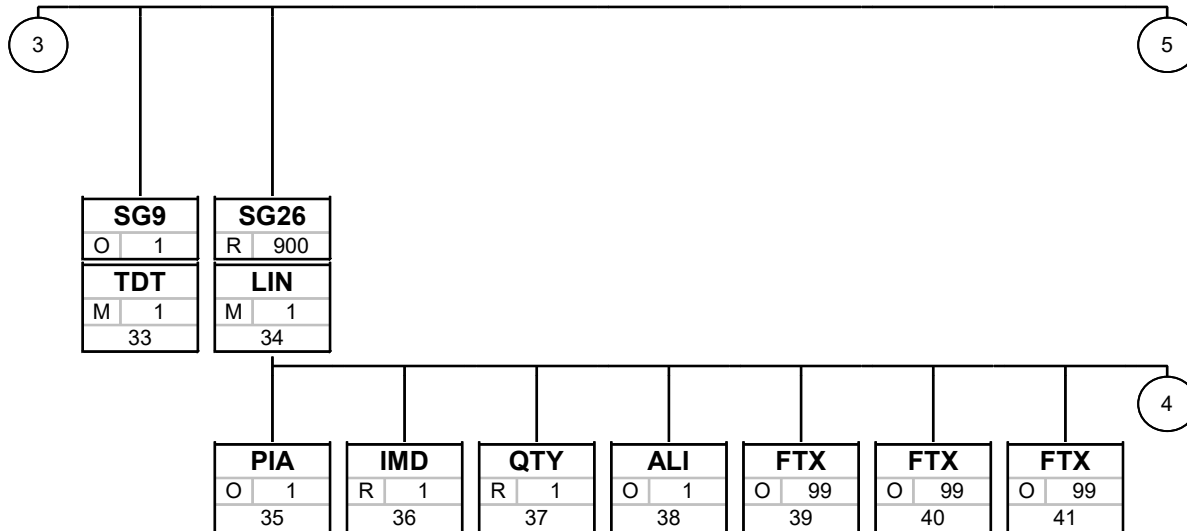

Tag
St MaxOcc
No

Tag = Segment/Group Tag
 St = Status: M=Mandatory, C=Conditional, R=Required, O=Optional, D=Dependent, A=Advised, N=Not used
 MaxOcc = Maximum occurrence of the segment/group
 No = Consecutive segment number

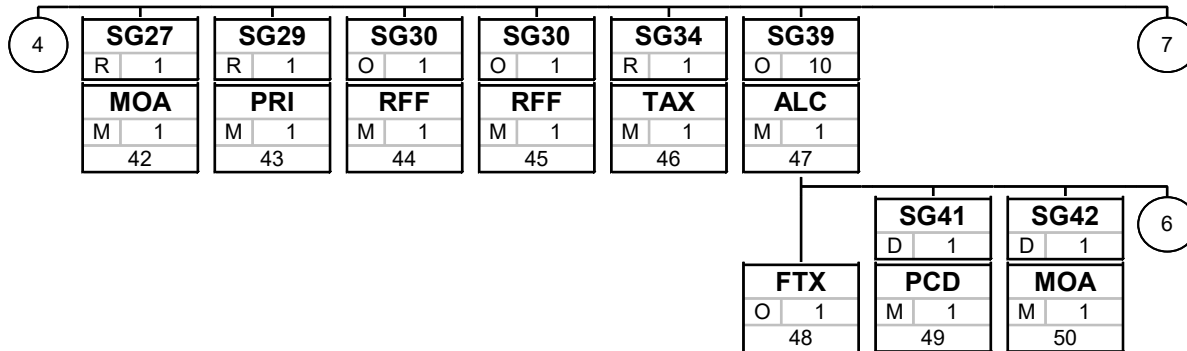

Tag
St MaxOcc
No

Tag = Segment/Group Tag
 St = Status: M=Mandatory, C=Conditional, R=Required, O=Optional, D=Dependent, A=Advised, N=Not used
 MaxOcc = Maximum occurrence of the segment/group
 No = Consecutive segment number

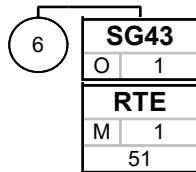

Tag
St MaxOcc
No

Tag = Segment/Group Tag
 St = Status: M=Mandatory, C=Conditional, R=Required, O=Optional, D=Dependent, A=Advised, N=Not used
 MaxOcc = Maximum occurrence of the segment/group
 No = Consecutive segment number

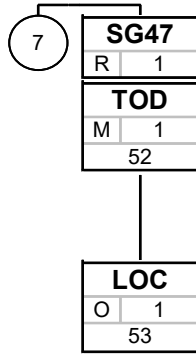

Tag
St MaxOcc
No

Tag = Segment/Group Tag
 St = Status: M=Mandatory, C=Conditional, R=Required, O=Optional, D=Dependent, A=Advised, N=Not used
 MaxOcc = Maximum occurrence of the segment/group
 No = Consecutive segment number

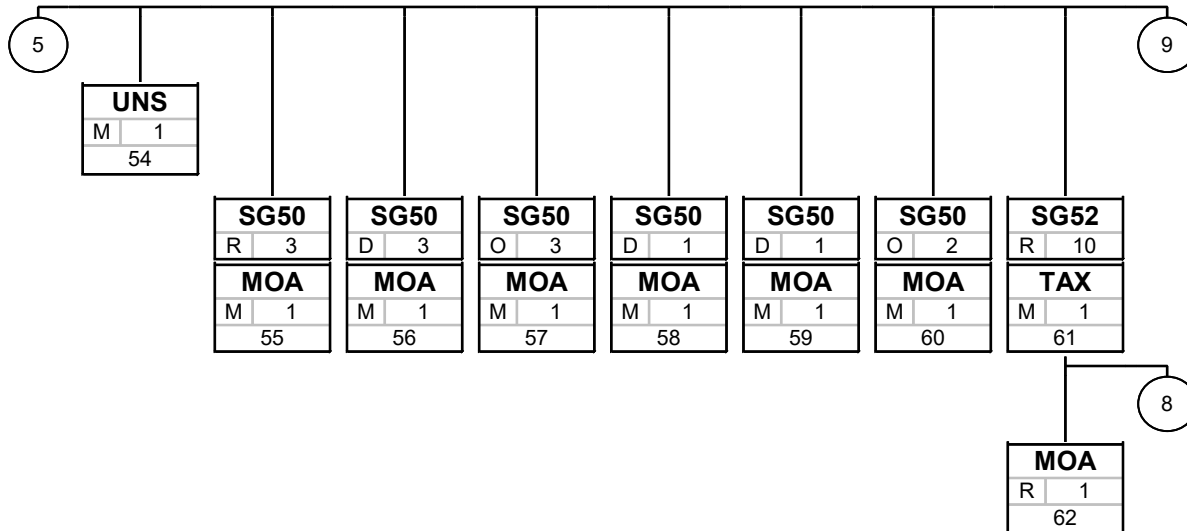

Tag
St MaxOcc
No

Tag = Segment/Group Tag
 St = Status: M=Mandatory, C=Conditional, R=Required, O=Optional, D=Dependent, A=Advised, N=Not used
 MaxOcc = Maximum occurrence of the segment/group
 No = Consecutive segment number

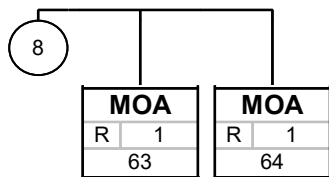

Tag
St MaxOcc
No

Tag = Segment/Group Tag
 St = Status: M=Mandatory, C=Conditional, R=Required, O=Optional, D=Dependent, A=Advised, N=Not used
 MaxOcc = Maximum occurrence of the segment/group
 No = Consecutive segment number

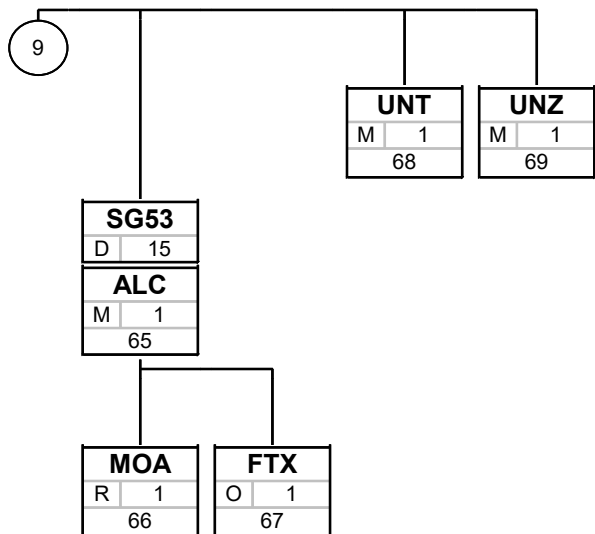

Tag	
St	MaxOcc
No	

Tag = Segment/Group Tag
 St = Status: M=Mandatory, C=Conditional, R=Required, O=Optional, D=Dependent, A=Advised, N=Not used
 MaxOcc = Maximum occurrence of the segment/group
 No = Consecutive segment number

Segments

Tag	St	MaxOcc
-----	----	--------

UNA	O	1 Service string advice
------------	---	-------------------------

EDIFACT			Conti		
Tag	Name	St Format	St	Format	Usage / Remark
UNA1	Component data element separator	M an1	M	an1	Colon
UNA2	Data element separator	M an1	M	an1	Plus sign
UNA3	Decimal notation	M an1	M	an1	Point
UNA4	Release indicator	M an1	M	an1	Question mark
UNA5	Reserved for future use	M an1	M	an1	Blank
UNA6	Segment terminator	M an1	M	an1	Apostrophe

Remark:

Example: UNA: + . ? '

MaxOcc = Maximum occurrence of the segment/group St = Status: M=Mandatory, C=Conditional, R=Required, O=Optional, D=Dependent, A=Advised, N=Not used



Tag	St	MaxOcc	
UNB	M	1	Interchange header

		EDIFACT	Conti		
Tag	Name	St Format	St	Format	Usage / Remark
S001	Syntax identifier	M	M		
0001	Syntax identifier	M a4	M	a4	UNOA UN/ECE level A 3 Version 3
0002	Syntax version number	M n1	M	n1	
S002	Interchange sender	M	M		
0004	Sender identification	M an..35	M	an..35	Unique ID of the sender in the data transmission network or system.
0007	Partner identification code qualifier	C an..4	O	an..4	
0008	Address for reverse routing	C an..14	O	an..14	Address of an application or internal system at sender's site to which answer messages should be routed.
S003	Interchange recipient	M	M		
0010	Recipient identification	M an..35	M	an..35	Unique ID of the receiver in the data transmission network or system.
0007	Partner identification code qualifier	C an..4	O	an..4	
0014	Routing address	C an..14	O	an..14	Address of an application or internal system at recipient's site.
S004	Date/time of preparation	M	M		
0017	Date of preparation	M n6	M	n6	Format YYMMDD
0019	Time of preparation	M n4	M	n4	Format HHMM
0020	Interchange control reference	M an..14	M	an..14	Unique ID of an interchange.
S005	Recipient's reference, password		N		
0022	Recipient's reference/password	an..14	N		Not used
0025	Recipient's reference/password qualifier	an2	N		Not used
0026	Application reference	an..14	N		Not used
0029	Processing priority code	a1	N		Not used
0031	Acknowledgement request	n1	N		Not used
0032	Communications agreement ID	an..35	N		Not used
0035	Test indicator	C n1	O	n1	1 Interchange is a test Only to be used, if the interchange is for test purposes. Omit this data element for valid interchanges.

Remark:

Example: UNB+UNOA:3+OD012345:59:123+987654321:1:X+071205:1446+144659+++++1'

MaxOcc = Maximum occurrence of the segment/group St = Status: M=Mandatory, C=Conditional, R=Required, O=Optional, D=Dependent, A=Advised, N=Not used

Tag	St	MaxOcc	
UNH	M	1	Message header

		EDIFACT	Conti		
Tag	Name	St Format	St	Format	Usage / Remark
0062	Message reference number	M an..14	M	an..14	Message reference number - unique number to identify the message within the interchange, usually a consecutive number starting with 1.
S009	Message identifier	M	M		
0065	Message type	M an..6	M	an..6	INVOIC Invoice message
0052	Message version number	M an..3	M	an..3	D Draft version/UN/EDIFACT Directory
0054	Message release number	M an..3	M	an..3	07A Release 2007 - A
0051	Controlling agency	M an..2	M	an..2	UN UN/CEFACT
0057	Association assigned code	C an6	R	an6	Identification of the subset release, assigned by the responsible organisation (Odette or member organisation). The code assigned by VDA should be used for a more exact specification of the applied subset.
0068	Common access reference	an..35	N		Not used
S010	Status of the transfer		N		
0070	Sequence of transfers	n..2	N		Not used
0073	First and last transfer	a1	N		Not used

Remark:

Example: UNH+1+INVOIC:D:07A:UN:GAVA12'

MaxOcc = Maximum occurrence of the segment/group St = Status: M=Mandatory, C=Conditional, R=Required, O=Optional, D=Dependent, A=Advised, N=Not used

Tag	St	MaxOcc
BGM	M	1 Type of invoice and invoice number

EDIFACT			Conti		
Tag	Name	St Format	St	Format	Usage / Remark
C002	Document/message name	C	R		
1001	Document name code	C an..3	R	an..3	The following explanations are intended to support a unique usage of the different message types: Table of transaction types and their results Code specifying the type or subtype of the business document. Use UN/EDIFACT code list 1001 and JAI code list JAI001 380 Commercial invoice 381 Credit note
1131	Code list identification code	an..17	N		Not used
3055	Code list responsible agency code	C an..3	O	an..3	272 Joint Automotive Industry agency Agency responsible for code list / identifier maintenance
1000	Document name	C an..35	O	an..35	Name of the document in text
C106	Document/message identification	C	R		
1004	Document identifier	C an..16	R	an..16	Invoice number
1056	Version identifier	an..9	N		Not used
1060	Revision identifier	an..6	N		Not used
1225	Message function code	C an..3	O	an..3	9 Original Code indicating the function of the document.
4343	Response type code	an..3	N		Not used

Remark:

Example: BGM+380:::272:Rechnung+Rechnungsnummer+9'

MaxOcc = Maximum occurrence of the segment/group St = Status: M=Mandatory, C=Conditional, R=Required, O=Optional, D=Dependent, A=Advised, N=Not used

Tag	St	MaxOcc
-----	----	--------

DTM	M	1 Message date
------------	---	----------------

EDIFACT			Conti		
Tag	Name	St Format	St	Format	Usage / Remark
C507	Date/time/period	M	M		
2005	Date or time or period function code qualifier	M an..3	M	an..3	The message date is perceived as synonym also for the invoice date. 137 Document issue date time
2380	Date or time or period text	C n8	R	n8	Date of the invoice document
2379	Date or time or period format code	C an..3	R	an..3	102 CCYYMMDD

Remark:

Example: DTM+137:20131125:102'

MaxOcc = Maximum occurrence of the segment/group St = Status: M=Mandatory, C=Conditional, R=Required, O=Optional, D=Dependent, A=Advised, N=Not used



Tag	St	MaxOcc
DTM	R	1 Delivery or Service Completion Date

EDIFACT			Conti		
Tag	Name	St Format	St	Format	Usage / Remark
C507	Date/time/period	M	M		
2005	Date or time or period function code qualifier	M an..3	M	an..3	1 Service completion date/time, actual
2380	Date or time or period text	C n..12	R	n..12	Service completion date
2379	Date or time or period format code	C an..3	R	an..3	102 CCYYMMDD

Remark:

In Europe, the invoice must contain the delivery or service date that is relevant for taxation purposes. Depending on the business process this can be the shipment date, the arrival date (receiving date) or even the consumption date. This segment is to be used to have one unique date that is not dependent on the individual process.

If an invoice contains line items with different tax rates for the same tax type (for instance the standard tax rate increases from 19% in month A to 21% in month B and the invoice covers line items of month A and B) then the allocation of tax amounts related to the different tax rates in the summary section and their allocation to different tax periods in the accounting system has to be done independently of the delivery or service completion date in the header.

Example: DTM+1:20100308:102'

MaxOcc = Maximum occurrence of the segment/group St = Status: M=Mandatory, C=Conditional, R=Required, O=Optional, D=Dependent, A=Advised, N=Not used

Tag	St	MaxOcc
FTX	O	99 Legal info free text

		EDIFACT	Conti			
Tag	Name	St	Format	St	Format	Usage / Remark
4451	Text subject code qualifier	M	an..3	M	an..3	REG Regulatory information TXD Tax declaration TXD is to be used for declaring the reason for tax exemption, valid for all line items. REG is to be used for information required by legislation (e.g. members of the board etc.).
4453	Free text function code		an..3	N		Not used
C107	Text reference			N		
4441	Free text description code		an..17	N		Not used
1131	Code list identification code		an..17	N		Not used
3055	Code list responsible agency code		an..3	N		Not used
C108	Text literal		C	R		
4440	Free text	M	an..256	M	an..256	A line of plain, non-structured text information.
4440	Free text	C	an..256	O	an..256	see 4440 # 1
4440	Free text	C	an..256	O	an..256	see 4440 # 1
4440	Free text	C	an..256	O	an..256	see 4440 # 1
4440	Free text	C	an..256	O	an..256	see 4440 # 1
3453	Language name code	C	an..3	O	an..3	Code specifying the language name. Use ISO 639-1988
4447	Free text format code		an..3	N		Not used

Remark:

Free text containing information or statements as required by legal environment.

Example: FTX+REG+++Text:Text:Text:Text:Text+de'

MaxOcc = Maximum occurrence of the segment/group St = Status: M=Mandatory, C=Conditional, R=Required, O=Optional, D=Dependent, A=Advised, N=Not used

Tag	St	MaxOcc
FTX	O	99 Payment instructions free text

EDIFACT			Conti		
Tag	Name	St Format	St	Format	Usage / Remark
4451	Text subject code qualifier	M an..3	M	an..3	AAB Payment term
4453	Free text function code	an..3	N		Not used
C107	Text reference		N		
4441	Free text description code	an..17	N		Not used
1131	Code list identification code	an..17	N		Not used
3055	Code list responsible agency code	an..3	N		Not used
C108	Text literal	C	R		
4440	Free text	M an..256	M	an..256	Terms of payment additional information
4440	Free text	C an..256	O	an..256	see 4440 # 1
4440	Free text	C an..256	O	an..256	see 4440 # 1
4440	Free text	C an..256	O	an..256	see 4440 # 1
4440	Free text	C an..256	C	an..256	see 4440 # 1
3453	Language name code	C an..3	O	an..3	Code specifying the language name. Use ISO 639-1988
4447	Free text format code	an..3	N		Not used

Remark:
Additional description of payment terms with free text.

Example: FTX+AAB+++Text:Text:Text:Text:Text+de'

MaxOcc = Maximum occurrence of the segment/group St = Status: M=Mandatory, C=Conditional, R=Required, O=Optional, D=Dependent, A=Advised, N=Not used

Tag	St	MaxOcc
FTX	O	99 General information free text

EDIFACT			Conti		
Tag	Name	St Format	St	Format	Usage / Remark
4451	Text subject code qualifier	M an..3	M	an..3	AAI General information
4453	Free text function code	an..3	N		Not used
C107	Text reference		N		
4441	Free text description code	an..17	N		Not used
1131	Code list identification code	an..17	N		Not used
3055	Code list responsible agency code	an..3	N		Not used
C108	Text literal	C	R		
4440	Free text	M an..256	M	an..256	A line of plain, non-structured text information.
4440	Free text	C an..256	O	an..256	see 4440 # 1
4440	Free text	C an..256	O	an..256	see 4440 # 1
4440	Free text	C an..256	O	an..256	see 4440 # 1
4440	Free text	C an..256	O	an..256	see 4440 # 1
3453	Language name code	C an..3	O	an..3	Code specifying the language name. Use ISO 639-1988
4447	Free text format code	an..3	N		Not used

Remark:

General information text

Example: FTX+AAI+++Text:Text:Text:Text:Text+de'

MaxOcc = Maximum occurrence of the segment/group St = Status: M=Mandatory, C=Conditional, R=Required, O=Optional, D=Dependent, A=Advised, N=Not used

Tag	St	MaxOcc
-----	----	--------

GEI O 1 Processing indicator

EDIFACT			Conti		
Tag	Name	St Format	St	Format	Usage / Remark
9649	Processing information code qualifier	M an..3	M	an..3	Codes have been defined by GIP in JAI013 code list - to be used with code 272 in DE 3055. Used to categorize the invoicing domain (production, other materials, services) (1) JAIF Code - to be used together with code 272 in data element 3055.
C012	Processing indicator	C	O		
7365	Processing indicator description code	an..3	N		Not used
1131	Code list identification code	an..17	N		Not used
3055	Code list responsible agency code	C an..3	R	an..3	272 Joint Automotive Industry agency
7364	Processing indicator description	an..35	N		Not used
7187	Process type description code	an..17	N		Not used

Remark:
This segment can be used to distinguish between production and non-production item invoices.

Example: GEI+PM+: :272'

MaxOcc = Maximum occurrence of the segment/group St = Status: M=Mandatory, C=Conditional, R=Required, O=Optional, D=Dependent, A=Advised, N=Not used



Tag	St	MaxOcc
SG2	R	1 Buyer
NAD	M	1 Buyer's Name and Address

EDIFACT			Conti		
Tag	Name	St Format	St	Format	Usage / Remark
3035	Party function code qualifier	M an..3	M	an..3	BY Buyer
C082	Party identification details	C	R		All partners listed in the invoicing message are to be transmitted with the complete name and address information. Partner ID is an additional information for enabling the automated processing and matching to internal records.
3039	Party identifier	M an..35	M	an..35	Unique identification of a party by an ID (customer number, supplier number, DUNS or similar).
1131	Code list identification code	an..17	N		Not used
3055	Code list responsible agency code	C an..3	R	an..3	91 Assigned by seller or seller's agent Agency responsible for code list / identifier maintenance
C058	Name and address		N		
3124	Name and address description	an..35	N		Not used
3124	Name and address description	an..35	N		Not used
3124	Name and address description	an..35	N		Not used
3124	Name and address description	an..35	N		Not used
3124	Name and address description	an..35	N		Not used
C080	Party name	C	R		
3036	Party name	M an..35	M	an..35	Single text line for specification of a name
3036	Party name	C an..35	O	an..35	see 3036 # 1
3036	Party name	an..35	N		Not used
3036	Party name	an..35	N		Not used
3036	Party name	an..35	N		Not used
3045	Party name format code	an..3	N		Not used
C059	Street	C	O		
3042	Street and number or post office box identifier	M an..35	M	an..35	The name that identifies the location of a house or building: usually within a street as part of an address.
3042	Street and number or post office box identifier	an..35	N		Not used
3042	Street and number or post office box identifier	an..35	N		Not used
3042	Street and number or post office box identifier	an..35	N		Not used
3164	City name	C an..35	R	an..35	The name of the city, town, or village of this address.
C819	Country subdivision details		N		
3229	Country subdivision identifier	an..9	N		Not used
1131	Code list identification code	an..17	N		Not used
3055	Code list responsible agency code	an..3	N		Not used
3228	Country subdivision name	an..70	N		Not used
3251	Postal identification code	C an..17	R	an..17	The identifier for one or more properties according to the postal service of that country; a group of letters and/or numbers added to the postal address to assist in the sorting of mail.
3207	Country identifier	C a2	R	a2	Provides the country part of an address using a code. Use ISO3166 two alpha code.

Remark:

Party to whom merchandise and/or service is sold.

Example: NAD+BY+Identifier::91++Name:Name+Strasse+Ort++PLZ+DE'

MaxOcc = Maximum occurrence of the segment/group St = Status: M=Mandatory, C=Conditional, R=Required, O=Optional, D=Dependent, A=Advised, N=Not used

Tag	St	MaxOcc	
SG3	R	1	Buyer's VAT reference number
RFF	M	1	Buyer's reference number(s)

EDIFACT			Conti		
Tag	Name	St Format	St	Format	Usage / Remark
C506	Reference	M	M		
1153	Reference code qualifier	M an..3	M	an..3	VA VAT registration number
1154	Reference identifier	C an..35	R	an..35	For 1153=VA: Unique number assigned by the relevant tax authority to identify a party for use in relation to Value Added Tax (VAT).
1156	Document line identifier	an..6	N		Not used
1056	Version identifier	an..9	N		Not used
1060	Revision identifier	an..6	N		Not used

Remark:**Example:** RFF+VA:7656444'

Tag	St	MaxOcc	
SG5	O	1	Information contact
CTA	M	1	Contact information

		EDIFACT	Conti		
Tag	Name	St Format	St	Format	Usage / Remark
3139	Contact function code	C an..3	R	an..3	IC Information contact
C056	Contact details	C	O		
3413	Contact identifier	C an..17	O	an..17	Identifies the department or employee by a unique identifier other than their name when given as a contact.
3412	Contact name	C an..35	O	an..35	Name of the contact person or department

Remark:

Example: CTA+IC+X:X'

MaxOcc = Maximum occurrence of the segment/group St = Status: M=Mandatory, C=Conditional, R=Required, O=Optional, D=Dependent, A=Advised, N=Not used

Tag	St	MaxOcc	
SG5	O	1	Information contact
COM	O	4	Communication contact

EDIFACT			Conti		
Tag	Name	St Format	St	Format	Usage / Remark
C076	Communication contact	M	M		
3148	Communication address identifier	M an..100	M	an..100	Buyer's Communication Number
3155	Communication means type code	M an..3	M	an..3	EM Electronic mail FX Telefax IM Internal mail TE Telephone

Remark:

Example: COM+08154711:TE'

MaxOcc = Maximum occurrence of the segment/group St = Status: M=Mandatory, C=Conditional, R=Required, O=Optional, D=Dependent, A=Advised, N=Not used



Tag	St	MaxOcc
SG2	R	1 Seller
NAD	M	1 Seller's name and address

EDIFACT			Conti		
Tag	Name	St Format	St	Format	Usage / Remark
3035	Party function code qualifier	M an..3	M	an..3	SE Seller
C082	Party identification details	C	R		All partners listed in the invoicing message are to be transmitted with the complete name and address information. Partner ID is an additional information for enabling the automated processing and matching to internal records.
3039	Party identifier	M an..35	R	an..35	Unique identification of a party by an ID (customer number, supplier number, DUNS or similar).
1131	Code list identification code	an..17	N		Not used
3055	Code list responsible agency code	C an..3	R	an..3	92 Assigned by buyer or buyer's agent Agency responsible for code list / identifier maintenance
C058	Name and address		N		
3124	Name and address description	an..35	N		Not used
3124	Name and address description	an..35	N		Not used
3124	Name and address description	an..35	N		Not used
3124	Name and address description	an..35	N		Not used
3124	Name and address description	an..35	N		Not used
C080	Party name	C	R		
3036	Party name	M an..35	M	an..35	Single text line for specification of a name
3036	Party name	C an..35	O	an..35	see 3036 # 1
3036	Party name	an..35	N		Not used
3036	Party name	an..35	N		Not used
3036	Party name	an..35	N		Not used
3045	Party name format code	an..3	N		Not used
C059	Street	C	O		
3042	Street and number or post office box identifier	M an..35	M	an..35	The name that identifies the location of a house or building: usually within a street as part of an address.
3042	Street and number or post office box identifier	an..35	N		Not used
3042	Street and number or post office box identifier	an..35	N		Not used
3042	Street and number or post office box identifier	an..35	N		Not used
3164	City name	C an..35	O	an..35	The name of the city, town, or village of this address.
C819	Country subdivision details		N		
3229	Country subdivision identifier	an..9	N		Not used
1131	Code list identification code	an..17	N		Not used
3055	Code list responsible agency code	an..3	N		Not used
3228	Country subdivision name	an..70	N		Not used
3251	Postal identification code	C an..17	R	an..17	The identifier for one or more properties according to the postal service of that country; a group of letters and/or numbers added to the postal address to assist in the sorting of mail.
3207	Country identifier	C a2	R	a2	Provides the country part of an address using a code. Use ISO3166 two alpha code.

Remark:

Party selling merchandise to a buyer.

Seller: The party who has liability to fulfill the contract. It is often used in the sense of seller and supplier and ship-from.

Example: NAD+SE+Identifier::92++Name:Name+Strasse+Ort++PLZ+DE'

MaxOcc = Maximum occurrence of the segment/group St = Status: M=Mandatory, C=Conditional, R=Required, O=Optional, D=Dependent, A=Advised, N=Not used

Tag	St	MaxOcc
SG3	O	1 Seller's VAT reference number(s)
RFF	M	1 Sellers's reference number(s)

EDIFACT			Conti		
Tag	Name	St Format	St	Format	Usage / Remark
C506	Reference	M	M		
1153	Reference code qualifier	M an..3	M	an..3	VA VAT registration number
1154	Reference identifier	C an..35	R	an..35	For 1153=VA: Unique number assigned by the relevant tax authority to identify a party for use in relation to Value Added Tax (VAT).
1156	Document line identifier	an..6	N		Not used
1056	Version identifier	an..9	N		Not used
1060	Revision identifier	an..6	N		Not used

Remark:

Example: RFF+VA:Umsatzsteuernummer des Verkäufers'

Tag	St	MaxOcc	
SG5	O	1	Information contact

Information that identifies the contact person or department on general matters, together with information about how they can be contacted.

CTA	M	1	Information contact
------------	---	---	----------------------------

EDIFACT			Conti		
Tag	Name	St Format	St	Format	Usage / Remark
3139	Contact function code	C an..3	C	an..3	IC Information contact
C056	Contact details	C	O		
3413	Contact identifier	C an..17	O	an..17	Identifies the department or employee by a unique identifier other than their name when given as a contact.
3412	Contact name	C an..35	O	an..35	Name of the contact person or department

Remark:

Information that identifies the contact person or department on general matters, together with information about how they can be contacted.

Example: CTA+IC+Abteilung:Name'

Tag	St	MaxOcc
-----	----	--------

SG5	O	1 Information contact
------------	---	------------------------------

Information that identifies the contact person or department on general matters, together with information about how they can be contacted.

COM	O	5 Communication contact
------------	---	--------------------------------

EDIFACT			Conti		
Tag	Name	St Format	St	Format	Usage / Remark
C076	Communication contact	M	M		
3148	Communication address identifier	M an..100	M	an..100	Communication number / address
3155	Communication means type code	M an..3	M	an..3	TE Telephone FX Telefax EM Electronic mail IM Internal mail

Remark:

Example: COM+08154711:TE'

MaxOcc = Maximum occurrence of the segment/group St = Status: M=Mandatory, C=Conditional, R=Required, O=Optional, D=Dependent, A=Advised, N=Not used



Tag	St	MaxOcc
SG2	R	1 Invoicee
NAD	M	1 Invoicee's name and address

EDIFACT			Conti		
Tag	Name	St Format	St	Format	Usage / Remark
3035	Party function code qualifier	M an..3	M	an..3	IV Invoicee
C082	Party identification details	C	O		All partners listed in the invoicing message are to be transmitted with the complete name and address information. Partner ID is an additional information for enabling the automated processing and matching to internal records.
3039	Party identifier	M an..35	M	an..35	Unique identification of a party by an ID (customer number, supplier number, DUNS or similar).
1131	Code list identification code	an..17	N		Not used
3055	Code list responsible agency code	C an..3	R	an..3	92 Assigned by buyer or buyer's agent Agency responsible for code list / identifier maintenance
C058	Name and address		N		
3124	Name and address description	an..35	N		Not used
3124	Name and address description	an..35	N		Not used
3124	Name and address description	an..35	N		Not used
3124	Name and address description	an..35	N		Not used
3124	Name and address description	an..35	N		Not used
C080	Party name	C	R		
3036	Party name	M an..35	M	an..35	Single text line for specification of a name
3036	Party name	C an..35	O	an..35	see 3036 # 1
3036	Party name	an..35	N		Not used
3036	Party name	an..35	N		Not used
3036	Party name	an..35	N		Not used
3045	Party name format code	an..3	N		Not used
C059	Street	C	O		
3042	Street and number or post office box identifier	M an..35	M	an..35	The name that identifies the location of a house or building: usually within a street as part of an address.
3042	Street and number or post office box identifier	an..35	N		Not used
3042	Street and number or post office box identifier	an..35	N		Not used
3042	Street and number or post office box identifier	an..35	N		Not used
3164	City name	C an..35	R	an..35	The name of the city, town, or village of this address.
C819	Country subdivision details		N		
3229	Country subdivision identifier	an..9	N		Not used
1131	Code list identification code	an..17	N		Not used
3055	Code list responsible agency code	an..3	N		Not used
3228	Country subdivision name	an..70	N		Not used
3251	Postal identification code	C an..17	R	an..17	The identifier for one or more properties according to the postal service of that country; a group of letters and/or numbers added to the postal address to assist in the sorting of mail.
3207	Country identifier	C a2	R	a2	Provides the country part of an address using a code. Use ISO3166 two alpha code.

Remark:

Party to whom the invoice is sent. This segment is only necessary if the invoicee differs from the buyer (respectively the seller in a self billed scenario).

Example: NAD+IV+Identifier::92++Name:Name+Strasse+Ort++PLZ+DE'

MaxOcc = Maximum occurrence of the segment/group St = Status: M=Mandatory, C=Conditional, R=Required, O=Optional, D=Dependent, A=Advised, N=Not used



Tag	St	MaxOcc
SG2	O	1 Invoice Issuer
NAD	M	1 Invoice Issuer's name and address

EDIFACT			Conti		
Tag	Name	St Format	St	Format	Usage / Remark
3035	Party function code qualifier	M an..3	M	an..3	II Invoice issuer
C082	Party identification details	C	O		All partners listed in the invoicing message are to be transmitted with the complete name and address information. Partner ID is an additional information for enabling the automated processing and matching to internal records.
3039	Party identifier	M an..35	M	an..35	Unique identification of a party by an ID (customer number, supplier number, DUNS or similar).
1131	Code list identification code	an..17	N		Not used
3055	Code list responsible agency code	C an..3	R	an..3	91 Assigned by seller or seller's agent 92 Assigned by buyer or buyer's agent Agency responsible for code list / identifier maintenance
C058	Name and address		N		
3124	Name and address description	an..35	N		Not used
3124	Name and address description	an..35	N		Not used
3124	Name and address description	an..35	N		Not used
3124	Name and address description	an..35	N		Not used
3124	Name and address description	an..35	N		Not used
C080	Party name	C	R		
3036	Party name	M an..35	M	an..35	Single text line for specification of a name
3036	Party name	C an..35	O	an..35	see 3036 # 1
3036	Party name	an..35	N		Not used
3036	Party name	an..35	N		Not used
3036	Party name	an..35	N		Not used
3045	Party name format code	an..3	N		Not used
C059	Street	C	O		
3042	Street and number or post office box identifier	M an..35	M	an..35	
3042	Street and number or post office box identifier	an..35	N		Not used
3042	Street and number or post office box identifier	an..35	N		Not used
3042	Street and number or post office box identifier	an..35	N		Not used
3164	City name	C an..35	O	an..35	
C819	Country subdivision details	C	O		
3229	Country subdivision identifier	C an..9	C	an..9	The name that identifies the location of a house or building: usually within a street as part of an address.
1131	Code list identification code	an..17	N		Not used
3055	Code list responsible agency code	an..3	N		Not used
3228	Country subdivision name	an..70	N		Not used
3251	Postal identification code	C an..17	O	an..17	see 3042 # 1
3207	Country identifier	C an..3	R	an..3	The name of the city, town, or village of this address.

Remark:

Party who issues the invoice. This segment is only necessary if the invoice issuer differs from the seller (respectively the buyer in a self billed scenario).

Example: NAD+II+Identifier::92++Name:Name+Strasse+Ort++PLZ+DE'

MaxOcc = Maximum occurrence of the segment/group St = Status: M=Mandatory, C=Conditional, R=Required, O=Optional, D=Dependent, A=Advised, N=Not used



Tag	St	MaxOcc
SG2	R	1 Ship-to
NAD	M	1 Ship-to's name and address

EDIFACT			Conti		
Tag	Name	St Format	St	Format	Usage / Remark
3035	Party function code qualifier	M an..3	M	an..3	ST Ship to
C082	Party identification details	C	O		All partners listed in the invoicing message are to be transmitted with the complete name and address information. Partner ID is an additional information for enabling the automated processing and matching to internal records.
3039	Party identifier	M an..35	R	an..35	In case of production materials deliveries this is usually the plant number of the receiving plant. Unique identification of a party by an ID (customer number, supplier number, DUNS or similar).
1131	Code list identification code	an..17	N		Not used
3055	Code list responsible agency code	C an..3	R	an..3	92 Assigned by buyer or buyer's agent Agency responsible for code list / identifier maintenance
C058	Name and address		N		
3124	Name and address description	an..35	N		Not used
3124	Name and address description	an..35	N		Not used
3124	Name and address description	an..35	N		Not used
3124	Name and address description	an..35	N		Not used
3124	Name and address description	an..35	N		Not used
C080	Party name	C	R		
3036	Party name	M an..35	M	an..35	Single text line for specification of a name
3036	Party name	C an..35	O	an..35	see 3036 # 1
3036	Party name	an..35	N		Not used
3036	Party name	an..35	N		Not used
3036	Party name	an..35	N		Not used
3045	Party name format code	an..3	N		Not used
C059	Street	C	O		
3042	Street and number or post office box identifier	M an..35	M	an..35	
3042	Street and number or post office box identifier	an..35	N		Not used
3042	Street and number or post office box identifier	an..35	N		Not used
3042	Street and number or post office box identifier	an..35	N		Not used
3164	City name	C an..35	O	an..35	
C819	Country subdivision details	C	O		
3229	Country subdivision identifier	C an..9	C	an..9	The name that identifies the location of a house or building: usually within a street as part of an address.
1131	Code list identification code	an..17	N		Not used
3055	Code list responsible agency code	an..3	N		Not used
3228	Country subdivision name	an..70	N		Not used
3251	Postal identification code	C an..17	O	an..17	see 3042 # 1
3207	Country identifier	C an..3	R	an..3	The name of the city, town, or village of this address.

Remark:

The party to which goods are to be shipped (consigned).

Example:

NAD+ST+Identifier::92++Name:Name+Strasse+Ort++PLZ+DE'

MaxOcc = Maximum occurrence of the segment/group St = Status: M=Mandatory, C=Conditional, R=Required, O=Optional, D=Dependent, A=Advised, N=Not used

Tag	St	MaxOcc	
SG5	O	1	Ship-to's delivery contact
CTA	M	1	Ship-to's delivery contact

		EDIFACT	Conti		
Tag	Name	St Format	St	Format	Usage / Remark
3139	Contact function code	C an..3	R	an..3	DL Delivery contact
C056	Contact details	C	O		
3413	Contact identifier	C an..17	O	an..17	Identifies the department or employee by a unique identifier other than their name when given as a contact.
3412	Contact name	C an..256	O	an..256	Name of the contact person or department

Remark:

A contact assigned to the delivery party

Example: CTA+DL+Abteilung:Name'

Tag	St	MaxOcc	
SG5	O	1	Ship-to's delivery contact
COM	O	1	Communication contact

EDIFACT			Conti		
Tag	Name	St Format	St	Format	Usage / Remark
C076	Communication contact	M	M		
3148	Communication address identifier	M an..100	M	an..100	Ship-to's contact communication number
3155	Communication means type code	M an..3	M	an..3	EM Electronic mail

Remark:

Example: COM+08154711:EM'

Tag	St	MaxOcc	
SG7	R	1	Invoice currency
CUX	M	1	Currencies

EDIFACT			Conti		
Tag	Name	St Format	St	Format	Usage / Remark
C504	Invoice currency	C	R		
6347	Currency usage code qualifier	M an..3	M	an..3	2 Reference currency
6345	Currency identification code	C an..3	R	an..3	Code specifying a monetary unit.
6343	Currency type code qualifier	C an..3	R	an..3	4 Invoicing currency
6348	Currency rate	n..4	N		Not used
C504	Currency details	C	C		
6347	Currency usage code qualifier	M an..3	M	an..3	
6345	Currency identification code	C an..3	C	an..3	
6343	Currency type code qualifier	C an..3	C	an..3	
6348	Currency rate	C n..4	C	n..4	
5402	Currency exchange rate	n..12	N		Not used
6341	Exchange rate currency market identifier	C an..3	C	an..3	

Remark:

A segment group combining a (source) currency and a target currency with the appropriate rate of exchange for those cases, where the transformation of currency is necessary.

If the invoicing currency is the official domestic currency, this segment group can be omitted (this may depend on national fiscal requirements). Otherwise it is used to state the necessary currencies.

It has to contain the invoice currency and may contain home or payment currency.

Invoicing currency is always to be given in the first occurrence of the CUX segment, C504#1 as follows:

6347: '2', 6345: currency, 6343: '4'

If a different payment or home currency is to be given, the second occurrence of C504 in the CUX segment is to be used as follows: second 6347: '3', second 6345: currency, and second 6343: '3' or '11'. Data element 5402 contains the currency conversion rate.

If three currencies have to be transmitted, another SG7 - CUX, DTM has to be created and the following rule shall apply:

SG7#1 CUX C504#1: invoice currency (see above)

SG7#1 CUX C504#2: payment currency (see above)

SG7#2 CUX C504#1: home currency (see below)

6347 '3' 6345 Currency 6343 '3'

Home currency: in some countries it is a requirement that, for invoicing in foreign currency, the invoice taxable and tax (e.g. VAT) amounts must also be expressed in home currency. Relating this to the CUX segments, authorities would require the invoicing currency and the home currency to be shown, together with the rate of exchange (element 5402).

Example: CUX+2:EUR:4+3:AED:1:9++AAA'

Tag	St	MaxOcc	
SG8	R	10	Payment instructions
PYT	M	1	Payment terms

EDIFACT			Conti		
Tag	Name	St Format	St	Format	Usage / Remark
4279	Payment terms type code qualifier	M an..3	M	an..3	1 Basic Qualifier for payment terms.
C019	Payment terms		N		
4277	Payment terms description identifier	an..17	N		Not used
1131	Code list identification code	an..17	N		Not used
3055	Code list responsible agency code	an..3	N		Not used
4276	Payment terms description	an..35	N		Not used
2475	Event time reference code	an..3	N		Payment Time Reference Coded - see code list 2475 Reference to the date of a specific event, e.g. issue date of a specified business document (for example invoice date). see code list 2475 Not used
2009	Terms time relation code	an..3	N		1 Reference date 2 Before reference 3 After reference 4 End of 10-day period containing the reference date 5 End of 2-week period containing the reference date 6 End of month containing the reference date 8 End of quarter containing the reference date 9 End of year containing the reference date 12 End of half year containing the reference date Code relating terms to a reference date, time or period. Not used
2151	Period type code	C an..3	O	an..3	3M Quarter 6M Half-year D Day M Month P Four month period W Week Y Year Code identifying a period
2152	Period count quantity	C n..3	O	n..3	Actual number of periods (days, weeks etc.) belonging to a payment term.

Remark:

Example: PYT+1++++D+90'

MaxOcc = Maximum occurrence of the segment/group St = Status: M=Mandatory, C=Conditional, R=Required, O=Optional, D=Dependent, A=Advised, N=Not used

Tag	St	MaxOcc	
SG8	R	10	Payment instructions
DTM	R	1	Payment due date

EDIFACT			Conti		
Tag	Name	St Format	St	Format	Usage / Remark
C507	Date/time/period	M	M		
2005	Date or time or period function code qualifier	M an..3	M	an..3	140 Payment due date
2380	Date or time or period text	C n8	R	n8	Date when the payment is due in order to comply with the specified payment terms.
2379	Date or time or period format code	C an..3	R	an..3	102 CCYYMMDD

Remark:

This segment can be used in conjunction with any of the applicable qualifiers in the leading PYT segment.

Example: DTM+140:20131212:102'

Tag	St	MaxOcc	
SG8	R	10	Payment instructions
DTM	O	1	Reference date/time

		EDIFACT	Conti		
Tag	Name	St Format	St	Format	Usage / Remark
C507	Date/time/period	M	M		
2005	Date or time or period function code qualifier	M an..3	M	an..3	171 Reference date/time
2380	Date or time or period text	C n8	R	n8	Date, the referenced document was issued, usually the invoice issue date
2379	Date or time or period format code	C an..3	R	an..3	102 CCYYMMDD

Remark:

The reference date is related to data element 2009 or code ZZZ in DE 2475 in the previous PYT segment. If data element 2009 is filled, this reference date has to be specified.

Example: DTM+171:20131212:102'

Tag	St	MaxOcc	
SG8	R	10	Payment instructions
PCD	R	1	Discount, payment or instalment percentage

EDIFACT			Conti		
Tag	Name	St Format	St	Format	Usage / Remark
C501	Percentage details	M	M		
5245	Percentage type code qualifier	M an..3	M	an..3	Payment Variation Qualifier 7 Prozentsatz einer Rechnung 12 Rabatt 122 Anteil an der Gesamtzahlung Code 7 must be used in conjunction with code 262 in the following MOA segment, DE 5025. Code 12 must be used in conjunction with code 52 in MOA, DE 5025. Code 122 requires code 77 in the MOA segment. Code 122 is used to indicate the percentages of the total payment that is covered by the payment means, which is specified in the triggering PYT segment.
5482	Percentage	C n..10	R	n..10	Amount expressed as a percentage deductible from the total amount due if payment takes place within a specified period or before the fixed due date. Percentage of an (e.g. invoice) total amount - used to specify e.g. payment variations or instalment payments. Amount expressed as a percentage added to the total amount due for payment.
5249	Percentage basis identification code	an..3	N		Not used
1131	Code list identification code	an..17	N		Not used
3055	Code list responsible agency code	an..3	N		Not used
4405	Status description code	an..3	N		Not used

Remark:

This segment specifies - dependent on qualifier of leading PYT segment - the discount percentage or the percentage of an invoice amount that an instalment is based on. The following MOA segment has to match this percentage, if given.

UK: Present HM Customs rules are that where invoice discounts (PYT/4279 = "22") are offered, based on a percentage of the invoice, then the percentage rate must also be explicitly declared - in such cases, the optional PCD segment would be mandatory for UK invoicing purposes. Please note also that, where (settlement) discounts are allowed, the VAT on the invoice is based on the discounted invoice amounts, irrespective of whether the terms of the discount are actually taken up by the Buyer.

Example: PCD+12:2'

MaxOcc = Maximum occurrence of the segment/group St = Status: M=Mandatory, C=Conditional, R=Required, O=Optional, D=Dependent, A=Advised, N=Not used

Tag	St	MaxOcc	
SG8	R	10	Payment instructions
MOA	O	1	Instalment or payment discount amount

EDIFACT			Conti		
Tag	Name	St Format	St	Format	Usage / Remark
C516	Monetary amount	M	M		
5025	Monetary amount type code qualifier	M an..3	M	an..3	52 Discount amount 262 Instalment amount
5004	Monetary amount	C n..15	R	n..15	Value of a discount amount in curreny units Value of an instalment monetary amount in curreny units Value of a penalty monetary amount in curreny units
6345	Currency identification code	C an..3	R	an..3	Code specifying a monetary unit.
6343	Currency type code qualifier	an..3	N		Not used
4405	Status description code	an..3	N		Not used

Remark:**Example:** MOA+52:9:EUR'

MaxOcc = Maximum occurrence of the segment/group St = Status: M=Mandatory, C=Conditional, R=Required, O=Optional,
D=Dependent, A=Advised, N=Not used

Tag	St	MaxOcc
-----	----	--------

SG8	R	10	Payment instructions
------------	---	----	----------------------

MOA	D	1	Monetary amount
------------	---	---	-----------------

EDIFACT			Conti		
Tag	Name	St Format	St	Format	Usage / Remark
C516	Monetary amount	M	M		
5025	Monetary amount type code qualifier	M an..3	M	an..3	372 Direct debit transfer amount
5004	Monetary amount	C n..35	R	n..35	
6345	Currency identification code	C an..3	O	an..3	
6343	Currency type code qualifier	an..3	N		Not used
4405	Status description code	an..3	N		Not used

Remark:

Example: MOA+372:9:EUR'

MaxOcc = Maximum occurrence of the segment/group St = Status: M=Mandatory, C=Conditional, R=Required, O=Optional, D=Dependent, A=Advised, N=Not used

Tag	St	MaxOcc	
SG8	R	10	Payment instructions
PAI	D	1	Payment instructions

EDIFACT			Conti		
Tag	Name	St Format	St	Format	Usage / Remark
C534	Payment instruction details	M	M		
4439	Payment conditions code	an..3	N		Not used
4431	Payment guarantee means code	an..3	N		Not used
4461	Payment means code	C an..3	R	an..3	49 Direct debit
1131	Code list identification code	an..17	N		Not used
3055	Code list responsible agency code	an..3	N		Not used
4435	Payment channel code	an..3	N		Not used

Remark:**Example:** PAI+::49'

MaxOcc = Maximum occurrence of the segment/group St = Status: M=Mandatory, C=Conditional, R=Required, O=Optional, D=Dependent, A=Advised, N=Not used

Tag	St	MaxOcc	
SG8	R	10	Payment instructions
FII	R	1	Financial institution information

EDIFACT			Conti		
Tag	Name	St Format	St	Format	Usage / Remark
3035	Party function code qualifier	M an..3	M	an..3	RH Seller's financial institution
C078	Account holder identification	C	R		
3194	Account holder identifier	C an..35	R	an..35	IBAN / Account number at the financial institution where this account is held.
3192	Account holder name	C an..35	O	an..35	Name of the official account holder, as registered with a financial institution.
3192	Account holder name	an..35	N		Not used
6345	Currency identification code	an..3	N		Not used
C088	Institution identification	C	R		Details to identify or reference a financial institution according to legal and business requirements.
3433	Institution name code	C an..11	R	an..11	Bank identifier as assigned by S.W.I.F.T. organisation.
1131	Code list identification code	an..17	N		Not used
3055	Code list responsible agency code	C an..3	R	an..3	17 S.W.I.F.T.
3434	Institution branch identifier	C an..17	R	an..17	A unique number allocated to identify a financial institution.
1131	Code list identification code	an..17	N		Identifier of a code list, assigned by the responsible organisation or agency Not used
3055	Code list responsible agency code	an..3	N		Agency responsible for code list / identifier maintenance Not used
3432	Institution name	C an..70	R	an..70	The name of the financial institution
3436	Institution branch location name	an..70	N		Not used
3207	Country identifier	an..3	N		Not used

Remark:

Example: FII+RH+4433221100:Iron Parts Ltd.+10090000::17::::Volksbank'

MaxOcc = Maximum occurrence of the segment/group St = Status: M=Mandatory, C=Conditional, R=Required, O=Optional, D=Dependent, A=Advised, N=Not used

Tag	St	MaxOcc	
SG9	O	1	Transport details
TDT	M	1	Transport information

EDIFACT			Conti		
Tag	Name	St Format	St	Format	Usage / Remark
8051	Transport stage code qualifier	M an..3	M	an..3	12 At departure
8028	Conveyance Reference Number	C an..17	O	an..17	Unique reference to a certain journey or departure of a means of transport (generic term).
C220	Mode of transport	C	R		
8067	Transport mode name code	C an..3	R	an..3	Examples: C = Consolidation (which means the shipment is consolidated and possibly transferred to another truck prior to arrival at the ultimate destination, U = Private Parcel Service (vs. public parcel service). Public parcel in the US would be the US Postal Service and private parcel in the US would be United Parcel Service or Federal Express. Based on the transport information, the cost associated with the movement of the material varies (which might be initially paid by the supplier or redirected by the customer for billing purposes). Codes indicated with (1) belong to JAI002 code list. Code specifying the name of a mode of transport. 10 12 20 23 30 40 50 60 70 80 90
8066	Transport mode name	an..17	N		Not used
C001	Transport means		N		
8179	Transport means description code	an..8	N		Not used
1131	Code list identification code	an..17	N		Not used
3055	Code list responsible agency code	an..3	N		Not used
8178	Transport means description	an..17	N		Not used
C040	Carrier		N		
3127	Carrier identifier	an..17	N		Not used
1131	Code list identification code	an..17	N		Not used
3055	Code list responsible agency code	an..3	N		Not used
3126	Carrier name	an..35	N		Not used
8101	Transit direction indicator code	an..3	N		Not used
C401	Excess transportation information		N		
8457	Excess transportation reason code	an..3	N		Not used
8459	Excess transportation responsibility code	an..3	N		Not used
7130	Customer shipment	an..17	N		Not used

MaxOcc = Maximum occurrence of the segment/group St = Status: M=Mandatory, C=Conditional, R=Required, O=Optional, D=Dependent, A=Advised, N=Not used

		EDIFACT	Conti		
Tag	Name	St Format	St	Format	Usage / Remark
	authorisation identifier				
C222	Transport identification		N		
8213	Transport means identification name identifier	an..35	N		Not used
1131	Code list identification code	an..17	N		Not used
3055	Code list responsible agency code	an..3	N		Not used
8212	Transport means identification name	an..70	N		Not used
8453	Transport means nationality code	an..3	N		Not used
8281	Transport means ownership indicator code	an..3	N		Not used

Remark:

To specify the transport details such as mode of transport, means of transport, its conveyance reference number and the identification of the means of transport.

Example: TDT+12++20'

Tag	St	MaxOcc	
SG26	R	900	Line item section
LIN	M	1	Line item and article nubur

		EDIFACT	Conti		
Tag	Name	St Format	St	Format	Usage / Remark
1082	Line item identifier	C n..6	R	n..6	Sequential number generated by the sender to identify a line item within a message. It is recommended to start with value 1 and to increment by 1 for each new line.
1229	Action code	an..3	N		Not used
C212	Item number identification	C	O		
7140	Item identifier	C an..35	R	an..35	Information directly relating to the identification of an article by the buyer's identification system. Note: The term article is synonymous to the term item. In the global joint automotive guidelines the term article is used.
7143	Item type identification code	C an..3	R	an..3	IN Buyer's item number
1131	Code list identification code	an..17	N		Not used
3055	Code list responsible agency code	an..3	N		Not used
C829	Sub-line information		N		
5495	Sub-line indicator code	an..3	N		Not used
1082	Line item identifier	an..6	N		Not used
1222	Configuration level number	n..2	N		Not used
7083	Configuration operation code	an..3	N		Not used

Remark:

Line item level of an invoice document.

Example: LIN+1++1234567890:IN'

MaxOcc = Maximum occurrence of the segment/group St = Status: M=Mandatory, C=Conditional, R=Required, O=Optional, D=Dependent, A=Advised, N=Not used

Tag	St	MaxOcc
-----	----	--------

SG26	R	900 Line item section
-------------	---	-----------------------

PIA	O	1 Additional article identifier(s) 1
------------	---	--------------------------------------

EDIFACT			Conti		
Tag	Name	St Format	St	Format	Usage / Remark
4347	Product identifier code qualifier	M an..3	M	an..3	1 Additional identification
C212	Sellers Article Number	M	M		
7140	Item identifier	C an..35	R	an..35	Information directly relating to the identification of an item by the seller's identification system. Note: The term article is synonymous to the term item. In the global joint automotive guidelines the term article is used.
7143	Item type identification code	C an..3	R	an..3	SA Supplier's article number
1131	Code list identification code	an..17	N		Not used
3055	Code list responsible agency code	an..3	N		Not used
C212	Item number identification		N		
7140	Item identifier	an..35	N		Not used
7143	Item type identification code	an..3	N		Not used
1131	Code list identification code	an..17	N		Not used
3055	Code list responsible agency code	an..3	N		Not used
C212	Item number identification		N		
7140	Item identifier	an..35	N		Not used
7143	Item type identification code	an..3	N		Not used
1131	Code list identification code	an..17	N		Not used
3055	Code list responsible agency code	an..3	N		Not used
C212	Item number identification		N		
7140	Item identifier	an..35	N		Not used
7143	Item type identification code	an..3	N		Not used
1131	Code list identification code	an..17	N		Not used
3055	Code list responsible agency code	an..3	N		Not used
C212	Item number identification		N		
7140	Item identifier	an..35	N		Not used
7143	Item type identification code	an..3	N		Not used
1131	Code list identification code	an..17	N		Not used
3055	Code list responsible agency code	an..3	N		Not used

Remark:

Example: PIA+1+1234:SA'

MaxOcc = Maximum occurrence of the segment/group St = Status: M=Mandatory, C=Conditional, R=Required, O=Optional, D=Dependent, A=Advised, N=Not used

Tag	St	MaxOcc	
SG26	R	900	Line item section
IMD	R	1	Description of article or service

EDIFACT			Conti		
Tag	Name	St Format	St	Format	Usage / Remark
7077	Description format code	an..3	N		Not used
C272	Item characteristic		N		
7081	Item characteristic code	an..3	N		Not used
1131	Code list identification code	an..17	N		Not used
3055	Code list responsible agency code	an..3	N		Not used
C273	Item description	C	R		
7009	Item description code	an..17	N		Not used
1131	Code list identification code	an..17	N		Not used
3055	Code list responsible agency code	an..3	N		Not used
7008	Item description	C an..70	R	an..70	The short name or description of an article or service in plain text.
7008	Item description	an..256	N		Not used
3453	Language name code	an..3	N		Not used
7383	Surface or layer code	an..3	N		Not used

Remark:

Example: IMD+++:::Beschreibung'

Tag	St	MaxOcc	
SG26	R	900	Line item section
QTY	R	1	Invoiced quantity

EDIFACT			Conti		
Tag	Name	St Format	St	Format	Usage / Remark
C186	Quantity details	M	M		
6063	Quantity type code qualifier	M an..3	M	an..3	47 Invoiced quantity
6060	Quantity	M n..15	M	n..15	Invoiced quantity value
6411	Measurement unit code	C an..3	R	an..3	Code specifying the unit of measurement.

Remark:

The quantity invoiced is necessary for line items belonging to an invoice, credit or debit note.

Example: QTY+47:9:C62'

Tag	St	MaxOcc	
SG26	R	900	Line item section
ALI	O	1	Country of origin, customs information and booking key

EDIFACT			Conti		
Tag	Name	St Format	St	Format	Usage / Remark
3239	Country of origin identifier	C a2	O	a2	Country Of Origin Coded: Country in which goods have been produced or manufactured, according to criteria laid down for the purposes of application of the customs tariff, quantitative restrictions, etc.
9213	Duty regime type code	an..3	N		Not used
4183	Special condition code	an..3	N		Not used
4183	Special condition code	an..3	N		Not used
4183	Special condition code	an..3	N		Not used
4183	Special condition code	an..3	N		Not used
4183	Special condition code	an..3	N		Not used

Remark:

Example: ALI+DE'

MaxOcc = Maximum occurrence of the segment/group St = Status: M=Mandatory, C=Conditional, R=Required, O=Optional, D=Dependent, A=Advised, N=Not used

Tag	St	MaxOcc	
SG26	R	900	Line item section
FTX	O	99	Terms of delivery text

EDIFACT			Conti		
Tag	Name	St Format	St	Format	Usage / Remark
4451	Text subject code qualifier	M an..3	M	an..3	AAR Terms of delivery
4453	Free text function code	an..3	N		Not used
C107	Text reference		N		
4441	Free text description code	an..17	N		Not used
1131	Code list identification code	an..17	N		Not used
3055	Code list responsible agency code	an..3	N		Not used
C108	Text literal	C	R		
4440	Free text	M an..256	R	an..256	A line of plain, non-structured text information concerning the delivery terms
4440	Free text	C an..256	O	an..256	see 4440 # 1
4440	Free text	C an..256	O	an..256	see 4440 # 1
4440	Free text	C an..256	O	an..256	see 4440 # 1
4440	Free text	C an..256	O	an..256	see 4440 # 1
3453	Language name code	C an..3	O	an..3	Code specifying the language name. Use ISO 639-1988
4447	Free text format code	an..3	N		Not used

Remark:

Terms agreed between the seller and the buyer under which the seller undertakes to deliver merchandise to a buyer, given in free text form.

Example: FTX+AAR+++Text:Text:Text:Text:Text+de'

Tag	St	MaxOcc	
SG26	R	900	Line item section
FTX	O	99	Tax exemption reason text

EDIFACT			Conti		
Tag	Name	St Format	St	Format	Usage / Remark
4451	Text subject code qualifier	M an..3	M	an..3	TXD Tax declaration
4453	Free text function code	an..3	N		Not used
C107	Text reference		N		
4441	Free text description code	an..17	N		Not used
1131	Code list identification code	an..17	N		Not used
3055	Code list responsible agency code	an..3	N		Not used
C108	Text literal	C	R		
4440	Free text	M an..256	M	an..256	Tax exemption reason text (reference to the provision in the EU directive in text)
4440	Free text	C an..256	O	an..256	See DE 4440 #1
4440	Free text	C an..256	O	an..256	See DE 4440 #1
4440	Free text	C an..256	O	an..256	See DE 4440 #1
4440	Free text	C an..256	O	an..256	See DE 4440 #1
3453	Language name code	C an..3	O	an..3	Code specifying the language name. Use ISO 639-1988
4447	Free text format code	an..3	N		Not used

Remark:

Example: FTX+TXD+++Text:Text:Text:Text:Text+de'

MaxOcc = Maximum occurrence of the segment/group St = Status: M=Mandatory, C=Conditional, R=Required, O=Optional, D=Dependent, A=Advised, N=Not used

Tag	St	MaxOcc	
SG26	R	900	Line item section
FTX	O	99	General text information

EDIFACT			Conti		
Tag	Name	St Format	St	Format	Usage / Remark
4451	Text subject code qualifier	M an..3	M	an..3	AAI General information
4453	Free text function code	an..3	N		Not used
C107	Text reference		N		
4441	Free text description code	an..17	N		Not used
1131	Code list identification code	an..17	N		Not used
3055	Code list responsible agency code	an..3	N		Not used
C108	Text literal	C	R		
4440	Free text	M an..256	M	an..256	Other free text information, e.g. reason for goods return etc.
4440	Free text	C an..256	O	an..256	See DE 4440 #1
4440	Free text	C an..256	O	an..256	See DE 4440 #1
4440	Free text	C an..256	O	an..256	See DE 4440 #1
4440	Free text	C an..256	O	an..256	See DE 4440 #1
3453	Language name code	C an..3	O	an..3	Code specifying the language name. Use ISO 639-1988
4447	Free text format code	an..3	N		Not used

Remark:

Example: FTX+AAI+++Text:Text:Text:Text:Text+de'

MaxOcc = Maximum occurrence of the segment/group St = Status: M=Mandatory, C=Conditional, R=Required, O=Optional, D=Dependent, A=Advised, N=Not used

Tag	St	MaxOcc
SG27	R	1 Line item net amount
MOA	M	1 Line item net amount in invoice currency

EDIFACT			Conti		
Tag	Name	St Format	St	Format	Usage / Remark
C516	Monetary amount	M	M		
5025	Monetary amount type code qualifier	M an..3	M	an..3	203 Line item amount
5004	Monetary amount	C n..15	R	n..15	Value of line item net amount in currency units - for currency refer to CUX segment (invoice currency)
6345	Currency identification code	C an..3	R	an..3	Code specifying a monetary unit.
6343	Currency type code qualifier	an..3	N		Not used
4405	Status description code	an..3	N		Not used

Remark:

The line item amount is the total related to this line item. It includes rebates and additions but excludes payment discount and VAT.
 Calculation formula: Net price amount * invoiced quantity = (invoiced quantity * gross price) plus / minus allowances or charges.

Example: MOA+203:9:EUR'



Tag	St	MaxOcc	
SG29	R	1	Calculation net price
PRI	M	1	Price details

EDIFACT			Conti		
Tag	Name	St Format	St	Format	Usage / Remark
C509	Price information	C	R		
5125	Price code qualifier	M an..3	M	an..3	The price stated is the net price including allowances/charges. Allowances/charges may be stated for information only. AAA Calculation net
5118	Price amount	C n..15	R	n..15	Unit price amount in price currency units
5375	Price type code	an..3	N		Not used
5387	Price specification code	C an..3	O	an..3	The contract price is assumed to be the default net price. In retrospective price adjustments the old price (AAL), the new price (CON) and the price difference (ABM) can be used. CON Contract price
5284	Unit price basis quantity	C n..9	O	n..9	Basis on which the unit price/rate applies.
6411	Measurement unit code	C an..3	O	an..3	Code specifying the unit of measurement.
5213	Sub-line item price change operation code	an..3	N		Not used

Remark:

Price including allowances and charges (ALC), this represents the net price applicable to the line, it does also include any allowances/charges (ALCs) that may be applicable to the line and which are deductible from the gross price.

Example: PRI+AAA:9::CON::PCE'

MaxOcc = Maximum occurrence of the segment/group St = Status: M=Mandatory, C=Conditional, R=Required, O=Optional, D=Dependent, A=Advised, N=Not used

Tag	St	MaxOcc
SG30	O	1 Frame contract (blanket order) / Order / Purchase order
RFF	M	1 Frame contract (blanket order) / Order / Purchase order

EDIFACT			Conti		
Tag	Name	St Format	St	Format	Usage / Remark
C506	Reference	M	M		
1153	Reference code qualifier	M an..3	R	an..3	ON Order document identifier, buyer assigned Type of reference, coded In the context of this VDA recommendation the codes are to be interpreted as follows: ON = Frame contract (blanket order) / Order / Purchase order
1154	Reference identifier	C an..35	R	an..35	Unique identifier of the referenced document
1156	Document line identifier	C n..6	O	n..6	Sequential number generated by the sender to identify a line item within a message. It is recommended to start with value 1 and to increment by 1 for each new line.
1056	Version identifier	an..9	N		Not used
1060	Revision identifier	an..6	N		Not used

Remark:

Example: RFF+ON:Bestellnummer:1'

MaxOcc = Maximum occurrence of the segment/group St = Status: M=Mandatory, C=Conditional, R=Required, O=Optional, D=Dependent, A=Advised, N=Not used

Tag	St	MaxOcc	
SG30	O	1	Despatch note / delivery note (synonym)
RFF	M	1	Reference message number

EDIFACT			Conti		
Tag	Name	St Format	St	Format	Usage / Remark
C506	Reference	M	M		
1153	Reference code qualifier	M an..3	R	an..3	AAU Despatch note document identifier Type of reference, coded
1154	Reference identifier	C an..35	R	an..35	Unique identifier of the referenced document
1156	Document line identifier	C n..6	O	n..6	Sequential number generated by the sender to identify a line item within a message. It is recommended to start with value 1 and to increment by 1 for each new line.
1056	Version identifier	an..9	N		Not used
1060	Revision identifier	an..6	N		Not used

Remark:

Example: RFF+AAU:Lieferscheinnummer:1'

MaxOcc = Maximum occurrence of the segment/group St = Status: M=Mandatory, C=Conditional, R=Required, O=Optional, D=Dependent, A=Advised, N=Not used

Tag	St	MaxOcc
SG34	R	1 VAT rate and amount for line item
TAX	M	1 VAT or other tax rate

EDIFACT			Conti		
Tag	Name	St Format	St	Format	Usage / Remark
5283	Duty or tax or fee function code qualifier	M an..3	M	an..3	7 Tax Code qualifying the function of a duty or tax or fee.
C241	Duty/tax/fee type	C	R		
5153	Duty or tax or fee type name code	C an..3	O	an..3	VAT Value added tax Code specifying a type of duty, tax or fee. Code OTH shall be used when the tax in question is not one of the listed. Code SUR is used to qualify the used part tax, which is additional to VAT (currently 10% of VAT amount due for the used part).
1131	Code list identification code	an..17	N		Not used
3055	Code list responsible agency code	an..3	N		Not used
5152	Duty or tax or fee type name	an..35	N		Not used
C533	Duty/tax/fee account detail		N		
5289	Duty or tax or fee account code	an..6	N		Not used
1131	Code list identification code	an..17	N		Not used
3055	Code list responsible agency code	an..3	N		Not used
5286	Duty or tax or fee assessment basis quantity	an..15	N		Not used
C243	Duty/tax/fee detail	C	R		
5279	Duty or tax or fee rate code	an..7	N		Not used
1131	Code list identification code	an..17	N		Not used
3055	Code list responsible agency code	an..3	N		Not used
5278	Duty or tax or fee rate	C n..7	R	n..7	The tax rate (numeric) should be presented as follows: 19.5% ==> :19.5 Rate (percentage) of the specified tax.
5273	Duty or tax or fee rate basis code	an..12	N		Not used
1131	Code list identification code	an..17	N		Not used
3055	Code list responsible agency code	an..3	N		Not used
5305	Duty or tax or fee category code	C an..3	O	an..3	Under EU directive and national law, any exemption from tax has to be declared more detailed. There are several provisions in the directive, which allow exemption. In the European environment it is necessary to state this reason whenever the invoice issuer declares an invoice item or the whole invoice to be VAT exempt. Code specifying a duty or tax or fee category. This code list contains codes referencing to the Sixth EU directive regarding tax exemption and special procedures. It is intended to be harmonised with other European industry organisations and finally the codes shall be added to the UN/EDIFACT code list 5305 to facilitate a homogeneous implementation of the directive's provisions throughout Europe. The use of any valid EDIFACT code is permitted, the trading partners may limit the codes in accordance with business and legal requirements. (1) Codes created to comply with the European invoicing

MaxOcc = Maximum occurrence of the segment/group St = Status: M=Mandatory, C=Conditional, R=Required, O=Optional, D=Dependent, A=Advised, N=Not used

EDIFACT			Conti		
Tag	Name	St Format	St	Format	Usage / Remark
					directive. These codes are not yet part of the official EDIFACT code list. AA Lower rate AE E Exempt from tax H Higher rate O Services outside scope of tax S Standard rate Z Zero rated goods
3446	Party tax identifier	an..20	N		Not used
1227	Calculation sequence code	an..3	N		Not used
5307	Tax or duty or fee payment due date code	C an..3	O	an..3	1 Duty, tax or fee payment due on invoice payment date 2 Duty, tax or fee payment due on invoice issue date

Remark:

This segment group is required when VAT is calculated at the line item level. Tax identification is required at the line item level as different goods and services can be taxed at different rates. That concerns VAT as well as different intrastate or interstate tax rates in the US.

Example: TAX+7+VAT++++: :19+AA+++1'

Tag	St	MaxOcc	
SG39	O	10	Allowances or charges
ALC	M	1	Allowance/charge

EDIFACT			Conti		
Tag	Name	St Format	St	Format	Usage / Remark
5463	Allowance or charge code qualifier	M an..3	R	an..3	A Allowance C Charge
C552	Allowance/charge information		N		
1230	Allowance or charge identifier	an..35	N		Not used
5189	Allowance or charge identification code	an..3	N		Not used
4471	Settlement means code	an..3	N		Not used
1227	Calculation sequence code	an..3	N		Not used
C214	Special services identification	C	O		
7161	Special service description code	C an..3	R	an..3	Code specifying a special service. Codes according to EDIFACT code list 7161 or JA1032 are applicable. The actually used codes have to be agreed upon mutually.
1131	Code list identification code	an..17	N		Not used
3055	Code list responsible agency code	C an..3	O	an..3	6 UN/ECE (United Nations - Economic Commission for Europe) 272 Joint Automotive Industry agency
7160	Special service description	an..35	N		Not used
7160	Special service description	an..35	N		Not used

Remark:

The financial amount by which the price is adjusted, up or down, dependent on the quantity of delivery or delivery terms specified. Usually, this amount is specified either as a percentage or (exclusive) as a rate per supplied price unit.

Example: ALC+C+++AAK::272'

Tag	St	MaxOcc	
SG39	O	10	Allowances or charges
FTX	O	1	Allowance/charge description

EDIFACT			Conti		
Tag	Name	St Format	St	Format	Usage / Remark
4451	Text subject code qualifier	M an..3	M	an..3	ALC Allowance/charge information
4453	Free text function code	an..3	N		Not used
C107	Text reference		N		
4441	Free text description code	an..17	N		Not used
1131	Code list identification code	an..17	N		Not used
3055	Code list responsible agency code	an..3	N		Not used
C108	Text literal	C	R		
4440	Free text	M an..256	M	an..256	Allowance or charge description in free text
4440	Free text	C an..256	O	an..256	see 4440 # 1
4440	Free text	C an..256	O	an..256	see 4440 # 1
4440	Free text	C an..256	O	an..256	see 4440 # 1
4440	Free text	C an..256	O	an..256	see 4440 # 1
3453	Language name code	C an..3	O	an..3	Code specifying the language name. Use ISO 639-1988
4447	Free text format code	an..3	N		Not used

Remark:

This segment is to be used, if allowance or charge cannot be transmitted with a code.

Example: FTX+ALC+++Text:Text:Text:Text:Text+de'

MaxOcc = Maximum occurrence of the segment/group St = Status: M=Mandatory, C=Conditional, R=Required, O=Optional, D=Dependent, A=Advised, N=Not used

Tag	St	MaxOcc	
SG41	D	1	Allowance/charge - percentage
PCD	M	1	Allowance/charge Percentage

EDIFACT			Conti		
Tag	Name	St Format	St	Format	Usage / Remark
C501	Percentage details	M	M		
5245	Percentage type code qualifier	M an..3	M	an..3	3 Monetary amount adjustment percentage
5482	Percentage	C n..10	R	n..10	Allowance or charge value is expressed as a percentage of a specified amount.
5249	Percentage basis identification code	an..3	N		Not used
1131	Code list identification code	an..17	N		Not used
3055	Code list responsible agency code	an..3	N		Not used
4405	Status description code	an..3	N		Not used

Remark:

Either SG41 (percentage) or SG42 (monetary amount) have to be sent.

Example: PCD+3:9'

Tag	St	MaxOcc	
SG42	D	1	Allowance/charge - monetary amount
MOA	M	1	Allowance/charge - monetary amount

EDIFACT			Conti		
Tag	Name	St Format	St	Format	Usage / Remark
C516	Monetary amount	M	M		
5025	Monetary amount type code qualifier	M an..3	M	an..3	8 Allowance or charge amount
5004	Monetary amount	C n..15	R	n..15	Allowance / Charge amount
6345	Currency identification code	C an..3	R	an..3	Code specifying a monetary unit.
6343	Currency type code qualifier	an..3	N		Not used
4405	Status description code	an..3	N		Not used

Remark:

Example: MOA+8:9:EUR'

Tag	St	MaxOcc
SG43	O	1 Allowance / charge rate per unit
RTE	M	1 Rate details

EDIFACT			Conti		
Tag	Name	St Format	St	Format	Usage / Remark
C128	Rate details	M	M		
5419	Rate type code qualifier	M an..3	M	an..3	1 Allowance rate 2 Charge rate
5420	Unit price basis rate	M n..15	M	n..15	Monetary amount rate used as allowance or charge per each supplied price unit.
5284	Unit price basis quantity	n..9	N		Not used
6411	Measurement unit code	an..8	N		Not used
4405	Status description code	an..3	N		Not used

Remark:

Example: RTE+1:10.00'

MaxOcc = Maximum occurrence of the segment/group St = Status: M=Mandatory, C=Conditional, R=Required, O=Optional, D=Dependent, A=Advised, N=Not used

Tag	St	MaxOcc	
SG47	R	1	Terms of delivery
TOD	M	1	Terms of delivery - incoterms

EDIFACT			Conti		
Tag	Name	St Format	St	Format	Usage / Remark
4055	Delivery or transport terms function code	an..3	N		Not used
4215	Transport charges payment method code	an..3	N		Not used
C100	Terms of delivery or transport	C	R		
4053	Delivery or transport terms description code	C a3	R	a3	CFR Cost and Freight CIF Cost, Insurance, Freight (... named port of destination) CIP Carriage and Insurance Paid to (... named place of destination) CPT Carriage Paid To (... named place of destination) DAF Delivered At frontier (... named place) DAP DAT DDP Delivered Duty Paid (... named place of destination) DDU Delivered Duty Unpaid (... named place of destination) DEQ Delivered Ex Quay (Duty paid) (... named port of destination) DES Delivered Ex Ship (... named port of destination) EXW Ex Works (... named place) FAS Free Along Ship (... named port of shipment) FCA Free Carrier (... named place) FOB Free On Board (... named port of shipment) Code specifying the delivery or transport terms.
1131	Code list identification code	an..17	N		Not used
3055	Code list responsible agency code	C an..3	O	an..3	4 ICC (International Chamber of Commerce) Agency responsible for code list / identifier maintenance
4052	Delivery or transport terms description	an..70	N		Not used
4052	Delivery or transport terms description	an..70	N		Not used

Remark:

Terms of delivery to be applied to the despatch or consignment to which they are related.

Example: TOD+++CFR::4'

MaxOcc = Maximum occurrence of the segment/group St = Status: M=Mandatory, C=Conditional, R=Required, O=Optional, D=Dependent, A=Advised, N=Not used

Tag	St	MaxOcc	
SG47	R	1	Terms of delivery
LOC	O	1	Place/location identification

EDIFACT			Conti		
Tag	Name	St Format	St	Format	Usage / Remark
3227	Location function code qualifier	M an..3	M	an..3	1 Place of terms of delivery
C517	Location identification	C	R		
3225	Location identifier	an..35	N		Not used
1131	Code list identification code	an..17	N		Not used
3055	Code list responsible agency code	an..3	N		Not used
3224	Location name	C an..35	R	an..35	Name of the INCOTERMS place
C519	Related location one identification		N		
3223	First related location identifier	an..35	N		Not used
1131	Code list identification code	an..17	N		Not used
3055	Code list responsible agency code	an..3	N		Not used
3222	First related location name	an..70	N		Not used
C553	Related location two identification		N		
3233	Second related location identifier	an..35	N		Not used
1131	Code list identification code	an..17	N		Not used
3055	Code list responsible agency code	an..3	N		Not used
3232	Second related location name	an..70	N		Not used
5479	Relation code	an..3	N		Not used

Remark:

Identification of the point or port of departure, shipment or destination as required under the applicable incoterms.

Example: LOC+1+:::Ort'

Tag	St	MaxOcc
UNS	M	1 Section control

EDIFACT			Conti		
Tag	Name	St Format	St	Format	Usage / Remark
0081	Section identification	M a1	M	a1	S Detail/summary section separation

Remark:

Example: UNS+S'

MaxOcc = Maximum occurrence of the segment/group St = Status: M=Mandatory, C=Conditional, R=Required, O=Optional, D=Dependent, A=Advised, N=Not used

Tag	St	MaxOcc	
SG50	R	3	Invoice amount
MOA	M	1	Invoice amount

EDIFACT			Conti		
Tag	Name	St Format	St	Format	Usage / Remark
C516	Monetary amount	M	M		
5025	Monetary amount type code qualifier	M an..3	M	an..3	77 Invoice line item amount
5004	Monetary amount	C n..15	R	n..15	Invoice total amount, including taxes (if applicable)
6345	Currency identification code	C an..3	R	an..3	Code specifying a monetary unit.
6343	Currency type code qualifier	an..3	N		Not used
4405	Status description code	an..3	N		Not used

Remark:

Total sum charged in respect of a single invoice in accordance with the terms of delivery.
 Invoice amount (MOA+77) is the sum of:
 line item amounts (MOA+79)
 plus total invoice additional amount (MOA+136)
 plus total duty/tax/fee amount (MOA+176)

Relation between Home Currency and Invoicing Currency is established through data element 5402 (rate of exchange) in the CUX segment at header level.

Example: MOA+77:1000:EUR'

Tag	St	MaxOcc
SG50	D	3 Total taxable amount
MOA	M	1 Total taxable amount

EDIFACT			Conti		
Tag	Name	St Format	St	Format	Usage / Remark
C516	Monetary amount	M	M		
5025	Monetary amount type code qualifier	M an..3	M	an..3	125 Taxable amount
5004	Monetary amount	C n..15	R	n..15	Value of taxable monetary amount in currency units
6345	Currency identification code	C an..3	R	an..3	Code specifying a monetary unit.
6343	Currency type code qualifier	an..3	N		Not used
4405	Status description code	an..3	N		Not used

Remark:

If no taxes or duties apply to any part of the invoice this occurrence of SG50 can be omitted. For transactions with European partners this SG50 might be required for legal reasons even if only zero rate taxes apply to the invoiced items.

Example: MOA+125:9:EUR'

MaxOcc = Maximum occurrence of the segment/group St = Status: M=Mandatory, C=Conditional, R=Required, O=Optional, D=Dependent, A=Advised, N=Not used

Tag	St	MaxOcc
SG50	O	3 Total line items amount
MOA	M	1 Total line items amount (sum of net line items amounts)

EDIFACT			Conti		
Tag	Name	St Format	St	Format	Usage / Remark
C516	Monetary amount	M	M		
5025	Monetary amount type code qualifier	M an..3	M	an..3	79 Total line items amount
5004	Monetary amount	C n..15	R	n..15	Total line items amount
6345	Currency identification code	C an..3	R	an..3	Code specifying a monetary unit.
6343	Currency type code qualifier	an..3	N		Not used
4405	Status description code	an..3	N		Not used

Remark:

Sum of all line items net amounts (MOA+203...)

Example: MOA+79:9:EUR'

MaxOcc = Maximum occurrence of the segment/group St = Status: M=Mandatory, C=Conditional, R=Required, O=Optional,
D=Dependent, A=Advised, N=Not used

Tag	St	MaxOcc
SG50	D	1 Total invoice additional amount
MOA	M	1 Total invoice additional amount

EDIFACT			Conti		
Tag	Name	St Format	St	Format	Usage / Remark
C516	Monetary amount	M	M		
5025	Monetary amount type code qualifier	M an..3	M	an..3	Amount Type 136 Total invoice additional amount
5004	Monetary amount	C n..15	R	n..15	Amount Total invoice additional amount
6345	Currency identification code	C an..3	R	an..3	Code specifying a monetary unit.
6343	Currency type code qualifier	an..3	N		Not used
4405	Status description code	an..3	N		Not used

Remark:

For the usage of this segment the following limitations apply:

1. This segment is only used for the sum of delivery costs (freight and packaing costs, SG 53).
2. This segmeng may be used only if all line items are subject to the same VAT rate.

In all other cases allowances and charges have to be allocated pro rata to the individual line items so that the actual net price is shown correctly.

If a charge is subject to a different VAT rate or cannot be allocated to the line items of the invoice, then a separate line item has to be generated with the charge and the correct VAT amount. The possibility of automatic validation of the invoice amounts has to be ensured.

Example: MOA+136:9:EUR'

Tag	St	MaxOcc
SG50	D	1 Tax amount
MOA	M	1 Tax amount

EDIFACT			Conti		
Tag	Name	St Format	St	Format	Usage / Remark
C516	Monetary amount	M	M		
5025	Monetary amount type code qualifier	M an..3	M	an..3	Amount Type 176 Message total duty/tax/fee amount
5004	Monetary amount	C n..15	R	n..15	Amount Total invoice additional amount
6345	Currency identification code	C an..3	R	an..3	Code specifying a monetary unit.
6343	Currency type code qualifier	an..3	N		Not used
4405	Status description code	an..3	N		Not used

Remark:

Example: MOA+176:9:EUR'

MaxOcc = Maximum occurrence of the segment/group St = Status: M=Mandatory, C=Conditional, R=Required, O=Optional, D=Dependent, A=Advised, N=Not used

Tag	St	MaxOcc
SG50	O	2 Non-taxable / exemption amount
MOA	M	1 Non-taxable or exemption amount

EDIFACT			Conti		
Tag	Name	St Format	St	Format	Usage / Remark
C516	Monetary amount	M	M		
5025	Monetary amount type code qualifier	M an..3	M	an..3	342 Non-taxable amount 403 Exemption amount
5004	Monetary amount	C n..15	R	n..15	Non taxable amount Value of a monetary amount subject to tax exemptions
6345	Currency identification code	C an..3	R	an..3	Code specifying a monetary unit.
6343	Currency type code qualifier	an..3	N		Not used
4405	Status description code	an..3	N		Not used

Remark:**Example:** MOA+403:9:EUR'

MaxOcc = Maximum occurrence of the segment/group St = Status: M=Mandatory, C=Conditional, R=Required, O=Optional,
D=Dependent, A=Advised, N=Not used

Tag	St	MaxOcc
SG52	R	10 Tax rates and amounts
TAX	M	1 Tax type and rate

EDIFACT			Conti		
Tag	Name	St Format	St	Format	Usage / Remark
5283	Duty or tax or fee function code qualifier	M an..3	M	an..3	7 Tax Code qualifying the function of a duty or tax or fee.
C241	Duty/tax/fee type	C	R		
5153	Duty or tax or fee type name code	C an..3	R	an..3	VAT Value added tax Code specifying a type of duty, tax or fee. Code SUR is used to qualify the used part tax, which is additional to VAT (currently 10% of VAT amount).
1131	Code list identification code	an..17	N		Not used
3055	Code list responsible agency code	an..3	N		Not used
5152	Duty or tax or fee type name	an..35	N		Not used
C533	Duty/tax/fee account detail		N		
5289	Duty or tax or fee account code	an..6	N		Not used
1131	Code list identification code	an..17	N		Not used
3055	Code list responsible agency code	an..3	N		Not used
5286	Duty or tax or fee assessment basis quantity	an..15	N		Not used
C243	Duty/tax/fee detail	C	R		
5279	Duty or tax or fee rate code	an..7	N		Not used
1131	Code list identification code	an..17	N		Not used
3055	Code list responsible agency code	an..3	N		Not used
5278	Duty or tax or fee rate	C n..7	R	n..7	The tax rate (numeric) should be presented in an alpha-numeric field as follows: 19.5% ==> :19.5 Rate (percentage) of the specified tax.
5273	Duty or tax or fee rate basis code	an..12	N		Not used
1131	Code list identification code	an..17	N		Not used
3055	Code list responsible agency code	an..3	N		Not used
5305	Duty or tax or fee category code	C an..3	D	an..3	Under 6th EU directive, any exemption from tax has to be declared more detailed. There are several provisions in the directive, which allow exemption. In the European environment it is necessary to state this reason whenever the invoice issuer declares an invoice item or the whole invoice to be VAT exempt. Code specifying a duty or tax or fee category. This code list contains codes referencing to the Sixth EU directive regarding tax exemption and special procedures. It is intended to be harmonised with other European industry organisations and finally the codes shall be added to the UN/EDIFACT code list 5305 to facilitate a homogeneous implementation of the directive's provisions throughout Europe. The use of any valid EDIFACT code is permitted, the trading partners may limit the codes in accordance with business and legal requirements. (1) Codes created to comply with the European invoicing directive. These codes are not yet part of the official EDIFACT code list. In Europe it is recommended or may be even required to use these more specific codes instead of code E.

MaxOcc = Maximum occurrence of the segment/group St = Status: M=Mandatory, C=Conditional, R=Required, O=Optional, D=Dependent, A=Advised, N=Not used

EDIFACT			Conti		
Tag	Name	St Format	St	Format	Usage / Remark
					Recommendation: A Mixed tax rate AA Lower rate E Exempt from tax H Higher rate O Services outside scope of tax S Standard rate Z Zero rated goods
3446	Party tax identifier	an..20	N		Not used
1227	Calculation sequence code	an..3	N		Not used
5307	Tax or duty or fee payment due date code	C an..3	O	an..3	1 Duty, tax or fee payment due on invoice payment date 2 Duty, tax or fee payment due on invoice issue date

Remark:

Example: TAX+7+VAT+++:::19++++1'

Tag	St	MaxOcc
SG52	R	10 Tax rates and amounts
MOA	R	1 Tax amount in invoice currency

EDIFACT			Conti		
Tag	Name	St Format	St	Format	Usage / Remark
C516	Monetary amount	M	M		
5025	Monetary amount type code qualifier	M an..3	M	an..3	124 Tax amount
5004	Monetary amount	C n..15	R	n..15	Value of a tax amount in currency units
6345	Currency identification code	C an..3	R	an..3	Code specifying a monetary unit.
6343	Currency type code qualifier	an..3	N		Not used
4405	Status description code	an..3	N		Not used

Remark:

Example: MOA+124:9:EUR'

Tag	St	MaxOcc
SG52	R	10 Tax rates and amounts
MOA	R	1 Taxable amount in invoice currency

EDIFACT			Conti		
Tag	Name	St Format	St	Format	Usage / Remark
C516	Monetary amount	M	M		
5025	Monetary amount type code qualifier	M an..3	M	an..3	125 Taxable amount
5004	Monetary amount	C n..15	R	n..15	Value of a taxable amount in currency units
6345	Currency identification code	C an..3	R	an..3	Code specifying a monetary unit.
6343	Currency type code qualifier	an..3	N		Not used
4405	Status description code	an..3	N		Not used

Remark:**Example:** MOA+125:9:EUR'

Tag	St	MaxOcc
SG52	R	10 Tax rates and amounts
MOA	R	1 Invoice amount in invoice currency

EDIFACT			Conti		
Tag	Name	St Format	St	Format	Usage / Remark
C516	Monetary amount	M	M		
5025	Monetary amount type code qualifier	M an..3	M	an..3	128 Total amount
5004	Monetary amount	C n..15	R	n..15	Value of a invoice amount in currency units
6345	Currency identification code	C an..3	R	an..3	Code specifying a monetary unit.
6343	Currency type code qualifier	an..3	N		Not used
4405	Status description code	an..3	N		Not used

Remark:

Example: MOA+128:9:EUR'

MaxOcc = Maximum occurrence of the segment/group St = Status: M=Mandatory, C=Conditional, R=Required, O=Optional, D=Dependent, A=Advised, N=Not used

Tag	St	MaxOcc	
SG53	D	15	Delivery costs
ALC	M	1	Charge

EDIFACT			Conti		
Tag	Name	St Format	St	Format	Usage / Remark
5463	Allowance or charge code qualifier	M an..3	M	an..3	C Charge
C552	Allowance/charge information		N		
1230	Allowance or charge identifier	an..35	N		Not used
5189	Allowance or charge identification code	an..3	N		Not used
4471	Settlement means code	an..3	N		Not used
1227	Calculation sequence code	an..3	N		Not used
C214	Special services identification	C	R		
7161	Special service description code	C an..3	R	an..3	ABK Miscellaneous ABM ABO ABP ABW FC Freight service FI Financing HD Handling IN PC Packing
1131	Code list identification code	an..17	N		Not used
3055	Code list responsible agency code	C an..3	O	an..3	272 Joint Automotive Industry agency
7160	Special service description	an..35	N		Not used
7160	Special service description	an..35	N		Not used

Remark:

This segment group is used for additional charge on invoice level (e.g. freight, packaging), i.e. in addition to charges that might be stated at individual line items. It is not the sum of line item charges.

Example: ALC+C++++ABK: : 272'

MaxOcc = Maximum occurrence of the segment/group St = Status: M=Mandatory, C=Conditional, R=Required, O=Optional, D=Dependent, A=Advised, N=Not used

Tag	St	MaxOcc
-----	----	--------

SG53	D	15 Delivery costs
-------------	---	-------------------

MOA	R	1 Charge amount
------------	---	-----------------

EDIFACT			Conti		
Tag	Name	St Format	St	Format	Usage / Remark
C516	Monetary amount	M	M		
5025	Monetary amount type code qualifier	M an..3	M	an..3	8 Allowance or charge amount
5004	Monetary amount	C n..35	R	n..35	Charge amount
6345	Currency identification code	C an..3	R	an..3	Code specifying a monetary unit.
6343	Currency type code qualifier	an..3	N		Not used
4405	Status description code	an..3	N		Not used

Remark:

Example: MOA+8:9:EUR'

MaxOcc = Maximum occurrence of the segment/group St = Status: M=Mandatory, C=Conditional, R=Required, O=Optional, D=Dependent, A=Advised, N=Not used

Tag	St	MaxOcc	
SG53	D	15	Delivery costs
FTX	O	1	Charge description text

EDIFACT			Conti		
Tag	Name	St Format	St	Format	Usage / Remark
4451	Text subject code qualifier	M an..3	M	an..3	ALC Allowance/charge information
4453	Free text function code	an..3	N		Not used
C107	Text reference		N		
4441	Free text description code	an..17	N		Not used
1131	Code list identification code	an..17	N		Not used
3055	Code list responsible agency code	an..3	N		Not used
C108	Text literal	C	R		
4440	Free text	M an..256	M	an..256	Additional charge description text
4440	Free text	C an..256	O	an..256	See DE 4440 #1
4440	Free text	C an..256	O	an..256	See DE 4440 #1
4440	Free text	C an..256	O	an..256	See DE 4440 #1
4440	Free text	C an..256	O	an..256	See DE 4440 #1
3453	Language name code	C an..3	O	an..3	Code specifying the language name. Use ISO 639-1988
4447	Free text format code	an..3	N		Not used

Remark:

Example: FTX+ALC+++Text:Text:Text:Text:Text+de'

MaxOcc = Maximum occurrence of the segment/group St = Status: M=Mandatory, C=Conditional, R=Required, O=Optional, D=Dependent, A=Advised, N=Not used

Tag	St	MaxOcc
UNT	M	1 Message trailer

EDIFACT			Conti		
Tag	Name	St Format	St	Format	Usage / Remark
0074	Number of segments in the message	M n..6	M	n..6	Number of segments in the message
0062	Message reference number	M an..14	M	an..14	

Remark:

Example: UNT+64+1'

MaxOcc = Maximum occurrence of the segment/group St = Status: M=Mandatory, C=Conditional, R=Required, O=Optional, D=Dependent, A=Advised, N=Not used

Tag	St	MaxOcc	
UNZ	M	1	Interchange trailer

EDIFACT			Conti		
Tag	Name	St Format	St	Format	Usage / Remark
0036	Interchange control count	M n..6	M	n..6	Number of messages in the data interchange.
0020	Interchange control reference	M an..14	M	an..14	Repetition of the value transmitted in UNB data element 0020.

Remark:

Example: UNZ+1+144659'

MaxOcc = Maximum occurrence of the segment/group St = Status: M=Mandatory, C=Conditional, R=Required, O=Optional, D=Dependent, A=Advised, N=Not used

Example Message

No	Tag	Example
01	UNA	UNA:+.? '
02	UNB	UNB+UNOA:3+OD012345:59:123+987654321:1:X+071205:1446+144659+++++1'
03	UNH	UNH+1+INVOIC:D:07A:UN:GAVA12'
04	BGM	BGM+380::272:Rechnung+Rechnungsnummer+9'
05	DTM	DTM+137:20131125:102'
06	DTM	DTM+1:20100308:102'
07	FTX	FTX+REG+++Text:Text:Text:Text:Text+de'
08	FTX	FTX+AAB+++Text:Text:Text:Text:Text+de'
09	FTX	FTX+AAI+++Text:Text:Text:Text:Text+de'
10	GEI	GEI+PM+::272'
	SG2	
11	NAD	NAD+BY+Identifler::91++Name:Name+Strasse+Ort++PLZ+DE'
	SG3	
12	RFF	RFF+VA:7656444'
	SG5	
13	CTA	CTA+IC+X:X'
14	COM	COM+08154711:TE'
	SG2	
15	NAD	NAD+SE+Identifler::92++Name:Name+Strasse+Ort++PLZ+DE'
	SG3	
16	RFF	RFF+VA:Umsatzsteuernummer des Verkäufers'
	SG5	
17	CTA	CTA+IC+Abteilung:Name'
18	COM	COM+08154711:TE'
	SG2	
19	NAD	NAD+IV+Identifler::92++Name:Name+Strasse+Ort++PLZ+DE'
	SG2	
20	NAD	NAD+II+Identifler::92++Name:Name+Strasse+Ort++PLZ+DE'
	SG2	
21	NAD	NAD+ST+Identifler::92++Name:Name+Strasse+Ort++PLZ+DE'
	SG5	
22	CTA	CTA+DL+Abteilung:Name'
23	COM	COM+08154711:EM'
	SG7	
24	CUX	CUX+2:EUR:4+3:AED:1:9+++AAA'
	SG8	

No = Consecutive segment number

No	Tag	Example
25	PYT	PYT+1++++D+90'
26	DTM	DTM+140:20131212:102'
27	DTM	DTM+171:20131212:102'
28	PCD	PCD+12:2'
29	MOA	MOA+52:9:EUR'
30	MOA	MOA+372:9:EUR'
31	PAI	PAI+:::49'
32	FII	FII+RH+4433221100:Iron Parts Ltd.+10090000:::17:::Volksbank'
SG9		
33	TDT	TDT+12++20'
SG26		
34	LIN	LIN+1++1234567890:IN'
35	PIA	PIA+1+1234:SA'
36	IMD	IMD+++:::Beschreibung'
37	QTY	QTY+47:9:C62'
38	ALI	ALI+DE'
39	FTX	FTX+AAR+++Text:Text:Text:Text:Text+de'
40	FTX	FTX+TXD+++Text:Text:Text:Text:Text+de'
41	FTX	FTX+AAI+++Text:Text:Text:Text:Text+de'
SG27		
42	MOA	MOA+203:9:EUR'
SG29		
43	PRI	PRI+AAA:9::CON::PCE'
SG30		
44	RFF	RFF+ON:Bestellnummer:1'
SG30		
45	RFF	RFF+AAU:Lieferscheinnummer:1'
SG34		
46	TAX	TAX+7+VAT+++:::19+AA+++1'
SG39		
47	ALC	ALC+C++++AAK:::272'
48	FTX	FTX+ALC+++Text:Text:Text:Text:Text+de'
SG41		
49	PCD	PCD+3:9'
SG42		
50	MOA	MOA+8:9:EUR'
SG43		

No = Consecutive segment number



No	Tag	Example
51	RTE	RTE+1:10.00'
	SG47	
52	TOD	TOD+++CFR::4'
53	LOC	LOC+1+:::Ort'
54	UNS	UNS+S'
	SG50	
55	MOA	MOA+77:1000:EUR'
	SG50	
56	MOA	MOA+125:9:EUR'
	SG50	
57	MOA	MOA+79:9:EUR'
	SG50	
58	MOA	MOA+136:9:EUR'
	SG50	
59	MOA	MOA+176:9:EUR'
	SG50	
60	MOA	MOA+403:9:EUR'
	SG52	
61	TAX	TAX+7+VAT+++:::19++++1'
62	MOA	MOA+124:9:EUR'
63	MOA	MOA+125:9:EUR'
64	MOA	MOA+128:9:EUR'
	SG53	
65	ALC	ALC+C+++ABK:::272'
66	MOA	MOA+8:9:EUR'
67	FTX	FTX+ALC+++Text:Text:Text:Text:Text+de'
68	UNT	UNT+64+1'
69	UNZ	UNZ+1+144659'

No = Consecutive segment number